

# PH OUTDOORS™

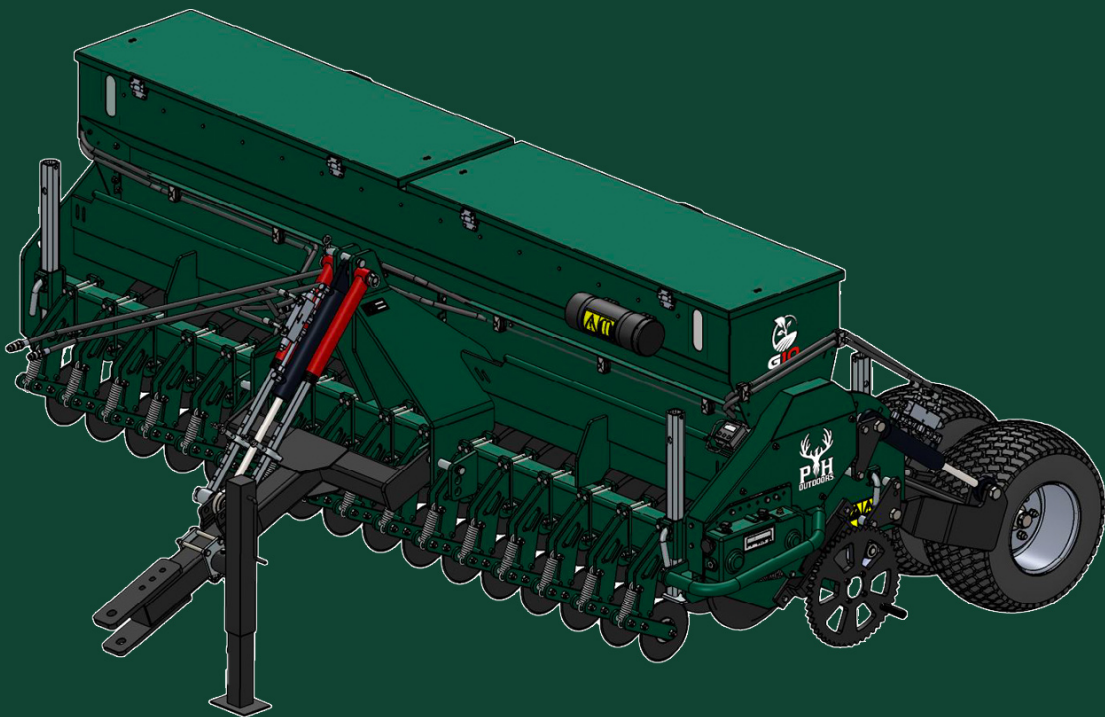

## G10 No-Till Drill Owners & User Manual

Serial # :



\*Illustrations may include optional items that are not included in standard package

**You will get the best performance and enjoyment from your new G10 No Till Drill by reading this instruction manual prior to operation.**

**Please keep this instruction manual handy for future reference. Doing so will allow you to understand and take advantage of the drills unique features and benefits.**



**The warranty of this product is one year from the date of purchase. Warranty terms and warranty card are on a separate page.**

Effective October 1, 2023

Welcome to the PH Outdoors family of users and congratulations with the purchase of your G10 no till drill. Your drill has been designed with care and built by skilled workers using quality materials. Proper setup, maintenance, and safe operating practices will help you get years of satisfactory use from the machine. It is of major importance to all users to read and understand this user manual. Operation of this machine is not safe without full knowledge of the content of the manual.

The G10 No Till Drill is not an independently operating machine. The user is responsible for selecting the appropriate tractor. The user must also check the tractor/drill combination for safety aspects, such as lift capacity, tire selection and operator training and any risks.

On the next page you will first find the general safety instructions. Every user must know and apply them. After this, a registration card is included. This card should be returned for handling any future claims.

This user manual offers many numbered instructions. A  symbol indicates a safety instruction. A  symbol indicates a tip and/or note.

At the time of publishing this manual all information and technical specifications provided are the most recent. Design specifications to the design of the machine may be changed without prior notice to help ensure safe and efficient operation. This manual familiarizes you with safety, assembly, operation, adjustments, troubleshooting, and maintenance. Read this manual and follow all recommendations.

THIS G10 NO TILL DRILL COMES WITH A GUARANTEE FOR DEFECTIVE MATERIALS. THIS GUARANTEE IS VALID FOR A PERIOD OF 12 MONTHS FROM THE PURCHASING DATE. PH OUTDOORS GUARANTEES ARE SUBJECT TO THE "GENERAL CONDITIONS FOR SUPPLY OF PLANT AND MACHINERY FOR EXPORT, NUMBER 188", PUBLISHED UNDER THE AUSPICES OF THE UNITED NATIONS ECONOMIC COMMISSION FOR EUROPE.

### **REGISTRATION CARD**

For your own information, please complete the table below:

Serial number of machine	
Dealer name	
Purchasing date	
Remarks	

Warranty registration can be completed at [PH-Outdoors.com](http://PH-Outdoors.com)

# ! SAFETY INSTRUCTIONS !



	<p><b>Reading and understanding</b> this manual familiarizes you with safety, assembly, operation, adjustments, troubleshooting, and maintenance. Read this manual and follow the recommendations to help ensure safe and efficient operation.</p> <p>The information in this manual is current at printing. Some parts may change to assure top performance.</p>
---	---

Figure 1

- (1) The G10 No Till Drill is designed for planting directly into areas with high plant residue such as food plots, pasture renovation, land reclamation, and more. Any other use is considered to be incorrect use. The manufacturer does not accept any liability with regard to damage resulting from incorrect use; all resulting risks are the responsibility of the user. Correct use also includes following the manufacturer's instructions for use, maintenance and repair.  Before using the G10, inspect the area to be planted. Remove any large obstacles from the planting area.
- (2) The G10 No Till Drill was constructed according to the latest technological knowledge and is safe to use. Improper use, maintenance or repair of the machine may result in injury to both the user and others. **This should always be avoided!**  
Always use the G10 No Till Drill in combination with the appropriate tractor as described in the technical data. If you need customer service or repair parts, contact an authorized PH Outdoors, LLC dealer. They have trained personnel, repair parts and equipment specially designed for our products.
- (3) All persons whom the owner assigns to operate, maintain or repair the G10 No Till Drill must read and completely understand the operating manual and in particular the **Safety Instructions** section. The owner and operator are responsible for a **safe tractor/drill combination**. The machine should ever be used in unsafe conditions.
- (4) Every time before using the G10 No Till Drill, the operator is **required** to inspect it for **visible damage and defects prior to operation**. Any changes of the G10 No Till Drill (including its functioning) that may affect its safety must be corrected immediately. For safety reasons it is forbidden to make modifications to the G10 No Till Drill (without the sole approval by the manufacturer). If any **modifications** have been made to the G10 No Till Drill, the warranty is null and void if any damages are a result from accident, abuse, or misapplication..

Inspect the G10 No Till Drill for loose bolts/nuts/parts before each use. If present, inspect the hydraulic hoses regularly and replace them if they are damaged or show signs of wear. The replacement hoses must meet the manufacturer's technical specifications.

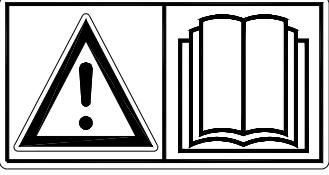

**Always** relieve the pressure from the hydraulic installation, if present, before carrying out any work on the hydraulic installation.



**NEVER** use the G10 No Till Drill when protective covers and safety decals are missing.



**NEVER** crawl under the G10 No Till Drill. Tilt the G10 if you need to have access to the underside of the machine.



**NEVER** step off the tractor while the engine is still running.



When carrying out maintenance activities, adjustments or repairs make sure the G10 is level and stable and can't move unintentionally.



When carrying out any maintenance activities, adjustments or repairs, **always switch off the tractor engine first and remove the tractor key from the ignition.**



Figure 2

Your machine's parts were specially designed and should only be replaced with OEM parts. Always use the serial and model number when ordering parts from your PH Outdoors, LLC dealer.

If you need customer service or repair parts, contact an authorized PH Outdoors, LLC dealer. They have trained personnel, repair parts and equipment specially designed for PH Outdoors, LLC products.

- (5) In addition to the instructions in this user manual, the generally applicable regulations with respect to safety and working conditions must be observed.



Comply with all national, regional and local safety laws when traveling on public roads.

**Transporting persons on the drill is not permitted!**



Do not use the G10 No Till Drill in unsafe weather conditions or on slopes with a gradient of more than 20 degrees.

- (6) Before starting to work, all persons operating the G10 No Till Drill must be familiar with all its functions and controls.



Connect the G10 Drill to the power unit that will pull it exactly according to the instructions (**Danger of injury!** Before operation be sure to have a clear view both nearby and far away.



On both sides of the G10, safety stickers have been applied to the side plates showing these warnings. Make sure these safety stickers are always clearly visible and legible. Replace them if they are damaged.



During operation, make sure there are **NO persons in the operating area** of the G10 No Till Drill to prevent them from getting injured by moving



Figure 3

**Keep a distance of at least 20 feet**



Figure 4

Be aware of the maximum lifting capacity of the towing vehicle for safe operating conditions. Otherwise the tractor can be too light in the front and steering can be effected.

Wear suitable clothing. Wear safe shoes with a steel tip, wear long trousers, and wear no loose clothing.

(7) Location of safety decals (Figure 5)

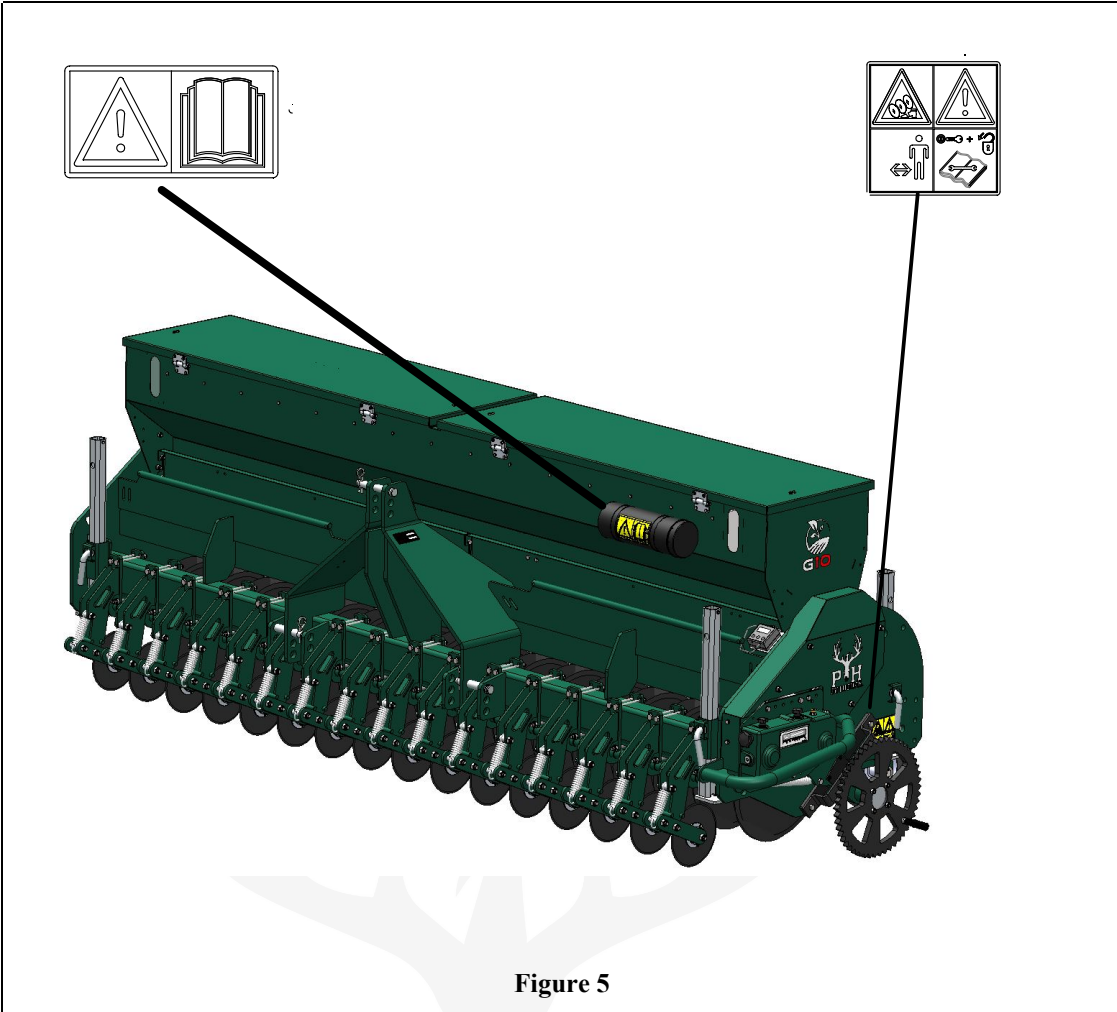

Figure 5

## CONTENTS

	FOREWORD	2
	GUARANTEE CONDITIONS	2
	REGISTRATION CARD	2
	SAFETY INSTRUCTIONS	3
1.0	TECHNICAL DATA	9
2.0	REMOVING THE MACHINE FROM THE TRANSPORT SKID	
3.0	CONNECTING TO TRACTOR	10
4.0	ADJUSTING THE WORKING DEPTH	11
5.0	SETTING SEED QUANTITY	12
5.1	CALIBRATION TEST	13
5.2	THE SEED ELEMENT VALVE OPENING	14
6.0	TRANSPORTING THE G10 NO TILL DRILL	16
7.0	DRIVING SPEED	17
8.0	GENERAL COMMENTS	17
9.0	OPERATING THE G10 NO TILL DRILL	17
10.0	START/STOP PROCEDURE	17
11.0	DISCONNECTING THE G10 NO TILL DRILL	18
12.0	TROUBLESHOOTING	19
13.0	MAINTENANCE	20
13.1	TECHNICAL INFORMATION: DIGITAL ACRE COUNTER	21
13.2	GREASE POINTS	21
14.0	ADJUSTING THE SPRING TENSION OF THE SIDE WHEEL	22
15.0	OPTIONAL EXTRAS: BOGY KIT	23
16.0	OPTIONAL EXTRAS: HYDRAULIC PUMP KIT	24

## 1.0 TECHNICAL DATA

<u>Model</u>	<u>G10 No Till Drill</u>
Working width	113"
Working depth	1/2" - 2"
Operating speed	Adjust to soil conditions
Weight	3,955 lbs)
Seeding row distance	7.5"
Number of cutting elements	16
Recommended tractor	120 HP with minimal lift capacity 24" behind the lift eyes of 5500 lbs)
Seed Hopper capacity	15.6 bushels
Dimensions	L x W x H 46" x 130" x 49"
Three-point connection	Three-point CAT 1-2
Optional parts	<ul style="list-style-type: none"> <li>• Hydraulic tow kit</li> <li>• Front Coulter knife kit.</li> <li>• Hydraulic pump kit.</li> <li>• Hopper dividers.</li> <li>• Seed Plates.</li> <li>• Weights</li> </ul>

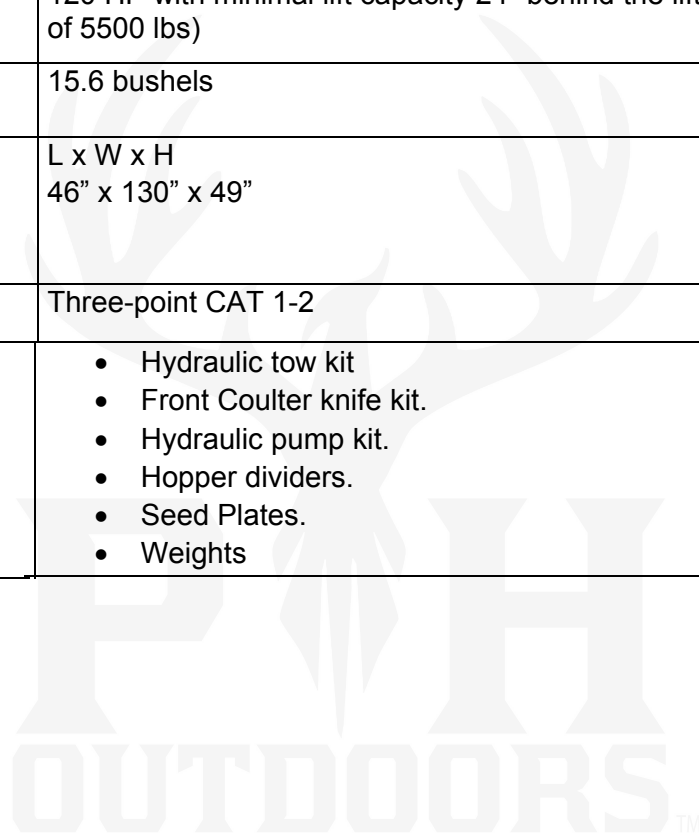



## 2.0 REMOVING THE MACHINE FROM THE TRANSPORT SKID

Perform the following actions to remove the machine from the pallet and place it horizontally on the floor (Figure 6)

**⚠ !! NEVER CRAWL UNDER THE MACHINE**

1. Attach a cable to the lifting points (1) on both sides of the machine.

**⚠ Make sure the cable/crane/lift has the capacity to lift at least 2400 lbs.**

2. Lift the machine, including the pallet, about 4" off the ground.
3. Remove the pallet by removing the bottom 3-point pins (2).
4. Pull the pallet away.
5. Turn the locking pins (3) half a rotation and remove them. Pull out the legs (4) and replace the locking pins(3).
6. Lower the machine in a controlled and slow way until it is fully on the ground.

**⚠ STAY AT A SAFE DISTANCE, THE MACHINE CAN SHIFT**

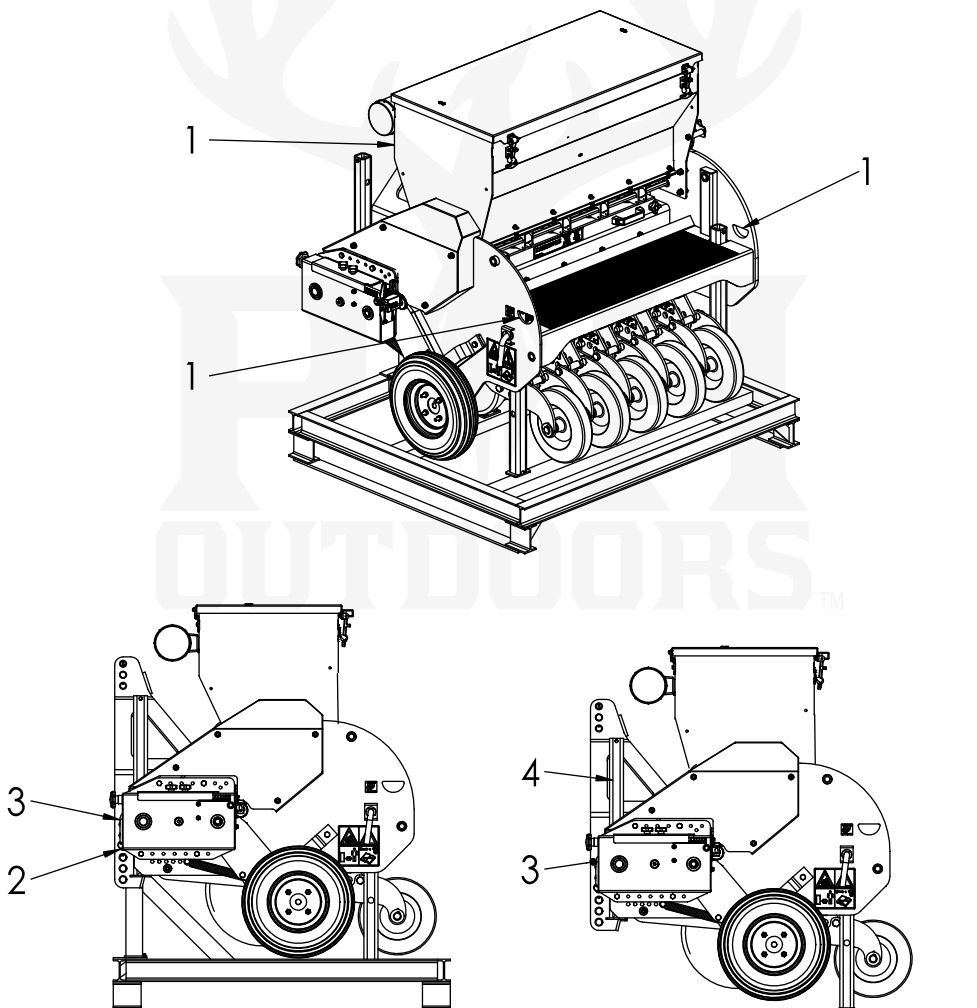

Figure 6

### 3.0 CONNECTING TO THE TRACTOR

Checks prior to connecting the G10 Drill:

- Check the G10 for any visual damage, and repair if safe operation of the machine cannot be guaranteed.
- Check whether all nuts and bolts have been tightened properly.
- Check whether all protective covers and safety stickers are in place on the machine, and whether they are undamaged. **NEVER** use the machine without them.

The G5/G8 drill can be connected to the tractor using the 3-point hitch. The method is as follows: (Figure 7)

1. Remove the 3-point pins (1 and 2).
2. Carefully back up the tractor, so that the lifting arms (4) can be connected to the frame.
- ⚠ Make sure the tractor is secured in place and cannot start moving**
- ⚠ Stop the engine of the tractor before getting off**
3. Connect the lifting arms to the bottom 3-point pins (2) and secure them using the included locking pins.
4. Set the stabilizer of the tractor to a 100 mm sideways stroke.
5. Mount the top link (3) of your tractor and extend it until it is at the same height as the top 3-point hitch (1) of the G10 drill.
6. Connect the top link (3) to the frame using the top pin (1) and secure using the included locking pin.
7. Keep extending/retracting the top link until the machine makes a 90° angle with the ground.
- ⚠ Make sure all locking pins are secured**
8. Start the tractor and lift the G10 drill off the ground.
9. Slide the support legs (5) up in the working position.

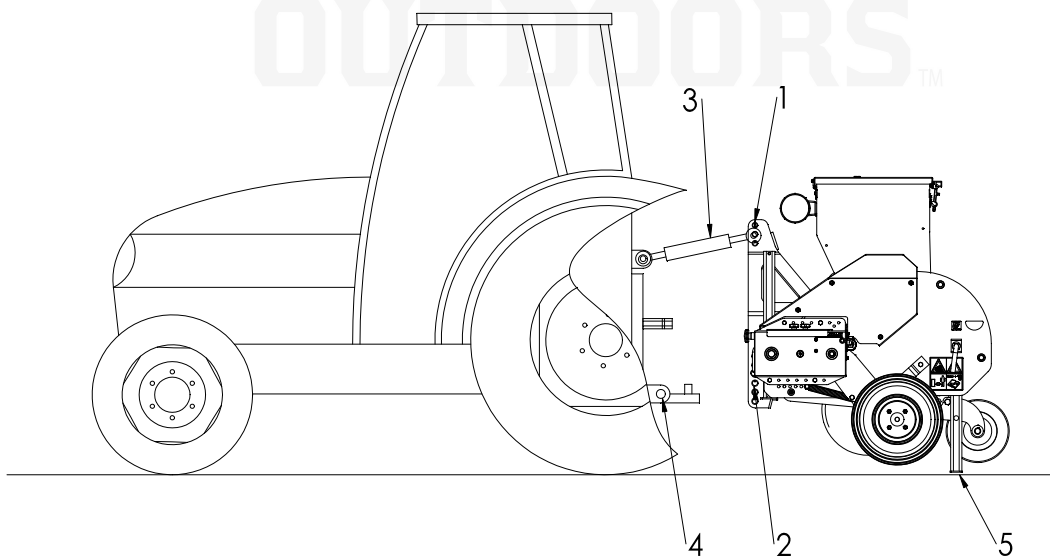

Figure 7

## 4.0 ADJUSTING THE WORKING DEPTH

The working depth can be adjusted by adjusting the pin on the rear wheel support. Remove the lower R-clip and pin (1) and place the pin in the hole for the right depth 0,5" - 1" - 2". After that lock the pin with the R-clip. (Figure 8)

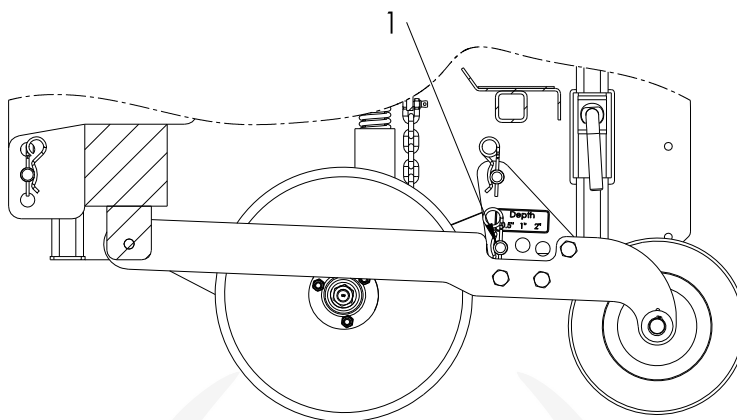

Figure 8

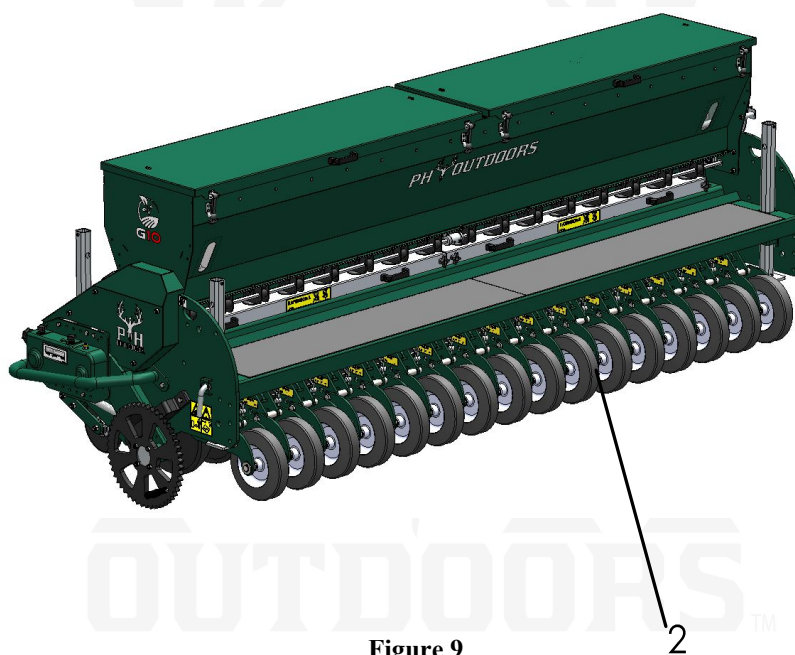

Figure 9



Please note that all wheels (2) are adjusted to the same depth before working with the machine. (Figure 9)



Additional depth adjustment can be made by screwing the top link of the tractor in or out as needed.



In extreme hard soil conditions the depth setting pins may be removed to try to achieve additional depth.

## 5.0 SETTING THE SEED-QUANTITY

The seed quantity can be set by changing the gearbox-ratio and the opening of the seed element valve (see chapter 5.2).

These settings provide various combinations for a wide range of settings. The gearbox has been marked with a decal, which indicates the numbers 1 to 11, also given in table 1. By changing the gearbox-ratio as indicated, the required quantity setting is obtained.

To change the gearbox-ratio, proceed as follows: (Figure 10)

- Loosen the knobs (1)
- Turn knob (2) to the required setting
- Tighten the knobs (1)

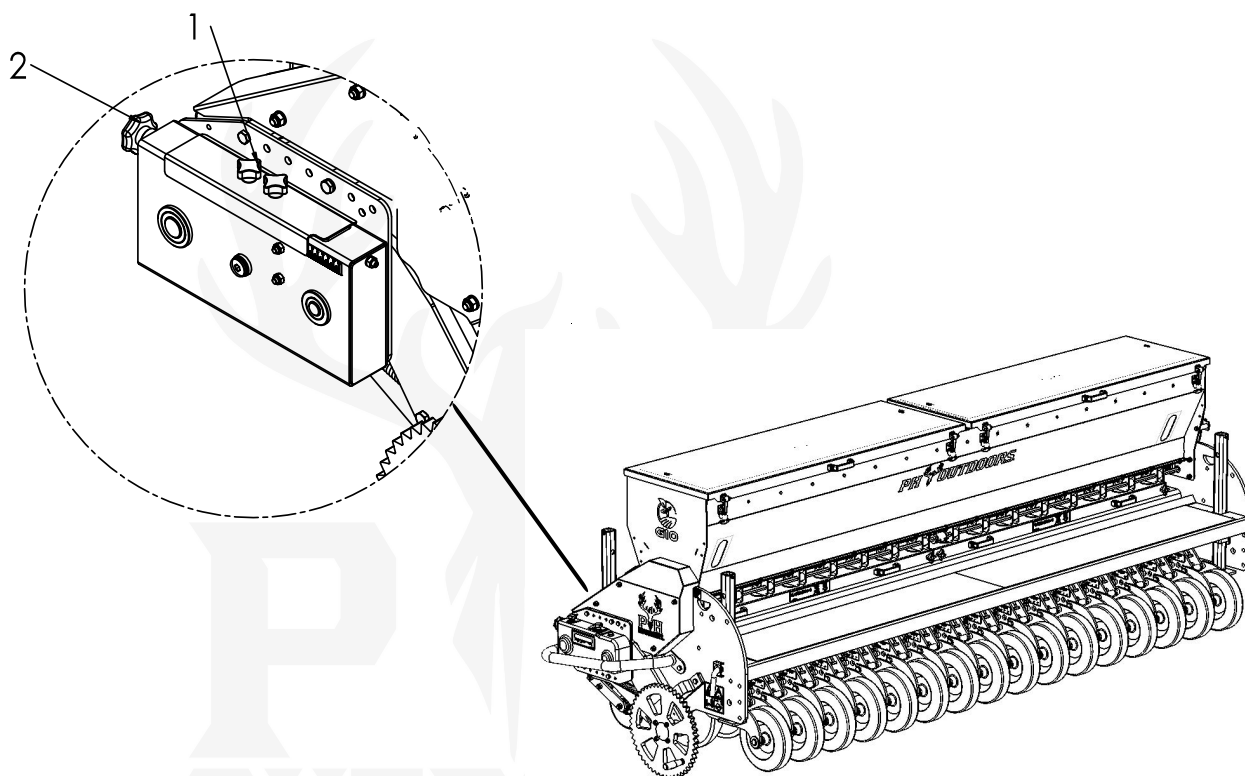

Figure 10

## 5.1. SEEDING CALIBRATION

If a calibration check needs to be done then follow the instructions below. (Figure 11)

1. Place the machine safely on the support legs on a flat surface.

**⚠ Make sure the tractor and G10 drill are secured in place**

**⚠ Switch the tractor off before getting off**

2. First of all check the seeding element valve opening for correct settings (see section 5.2).
3. Put the seed that has to be calibrated into the seed hopper and spread it out equally.
4. Remove the knobs (1) on both sides.
5. Take out the funnel tray (2).
6. Turn the funnel tray (2) upside down.
7. Slide the funnel tray (2) back into the machine and lock it with the knobs (1).
8. Turn the wheel (3) 26 full rotations counter clockwise and take out the funnel tray. Measure the total weight of the seed in pounds and multiply this by **41**.  
The result is the weight of the seeds in **pounds** that are seeded **per acre**.  
Use table 1 on the next page to write down the measured values.
9. Remount the parts in reverse order.



Don't start counting the 26 rotations until seed is dropping from each seed element

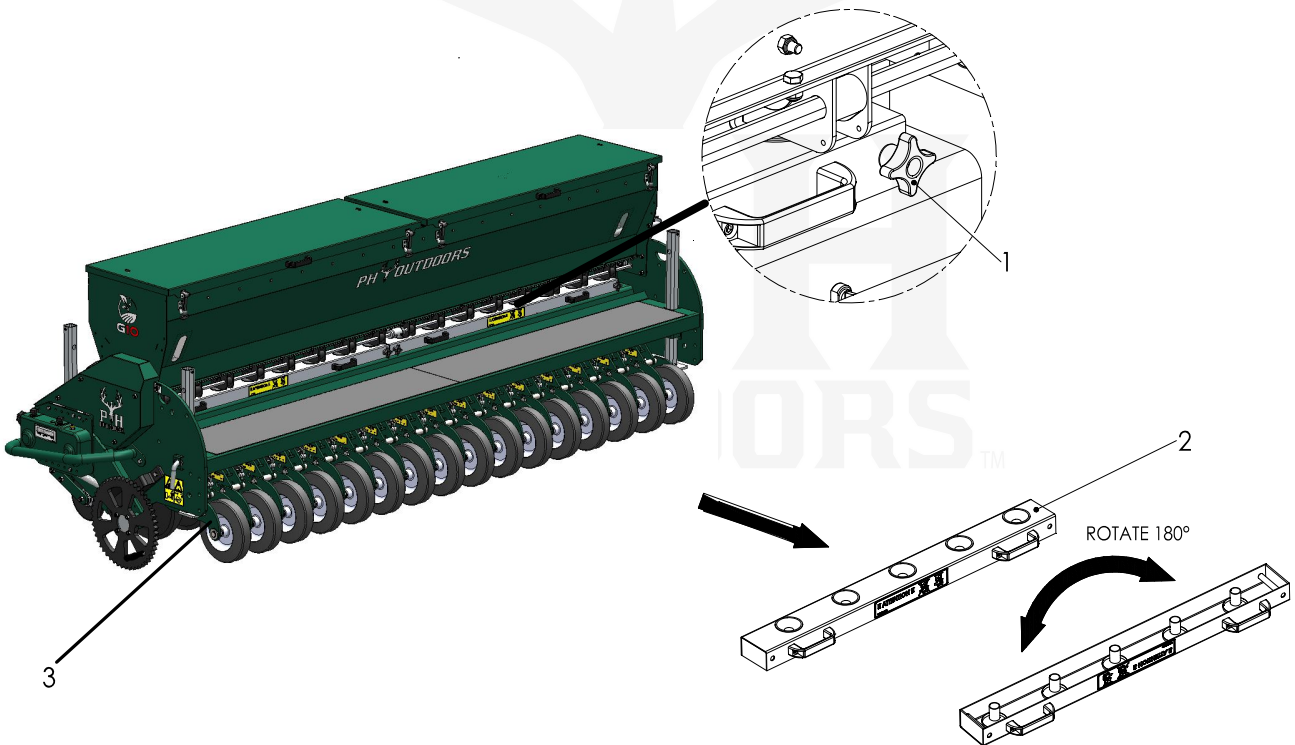

Figure 11

<b>Seeding table</b>			
<b>Gearbox setting</b> 	<b>Gate opening</b> 		
		<b>Kg/ha</b>	<b>Pound/Acre</b>
1			
2			
3			
4			
5			
6			
7			
8			
9			
10			
11			

Table 1



## 5.2. THE SEEDING ELEMENT VALVE OPENING

Changing the seeding element valve opening is done as follows: (see Figure 12)

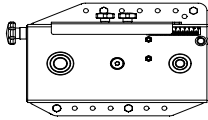
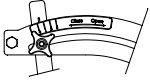
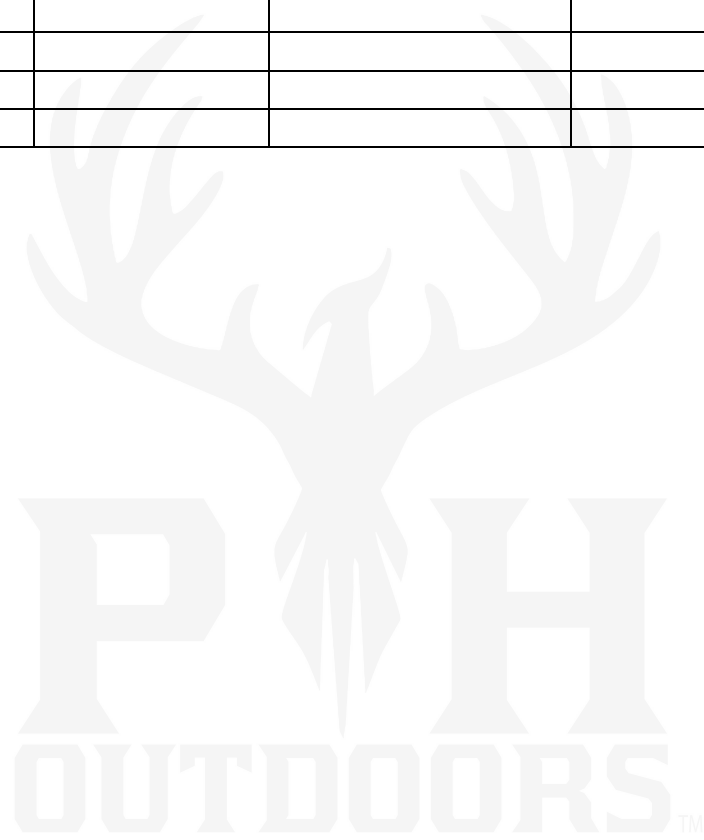
1. Loosen knob (1).
2. Adjust lever (2) with the knob by sliding it to open or closed.
3. Fasten the knob (1).

By default the seed element valve is closed.

The gate opening is depending on the seed size. When transporting the machine the seed element valve must be closed or seeds may spill out. Close the seed element valve before transporting the machine.

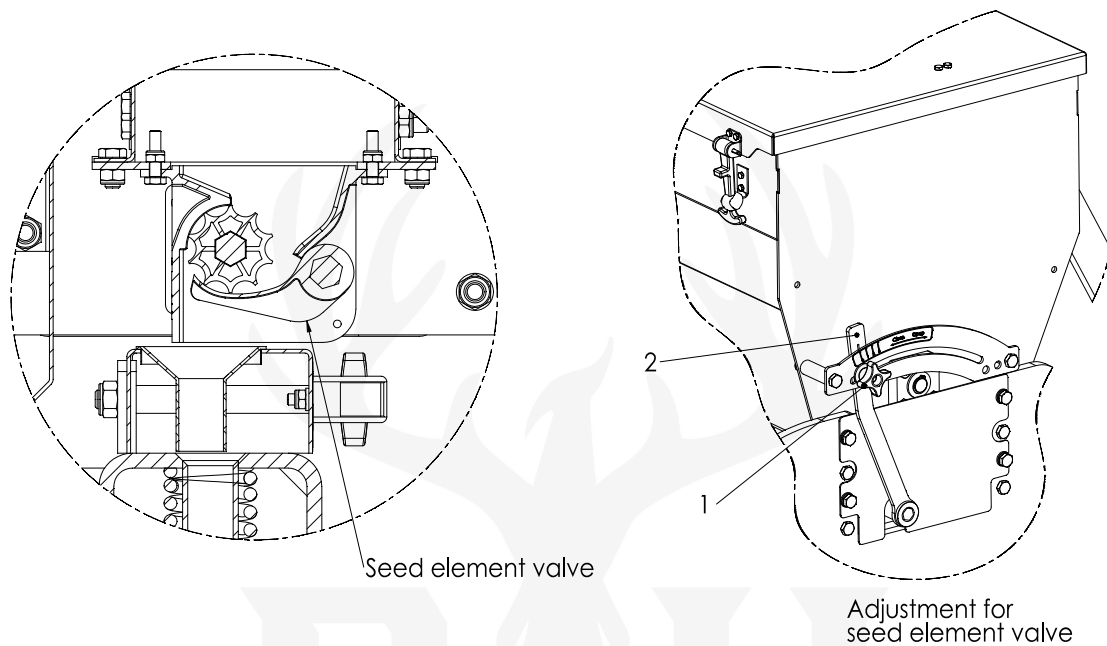



Figure 12



For cleaning the hopper and seed elements between seed varieties and after daily use open the valve completely then blow out the hopper with air. It highly recommended to avoid the use of coated seed.

## 6.0 TRANSPORTING THE G10 No Till Drill

 The user is responsible for the transport of the G10 drill behind the tractor when traveling on public roads. Comply with all national, regional and local safety laws when traveling on public roads. Due to the weight of the G10 drill, a maximum transport speed of 10 mph should be maintained while driving in open fields with the machine raised. Higher speeds may endanger the driver and/or other people and/or damage the machine.

 **When the G10 drill has been lifted off the ground, at least 20% of the weight of the tractor must rest on the front axle.**



If necessary, close the seeding element valve opening to prevent spilling seed (see section 5.2).

## 7.0 OPERATING SPEED

The operating speed while is limited by soil conditions and terrain. Higher speeds are not recommended and will result in excessive wear and damage to the machine, as well as poor seed to soil contact.

## 8.0 GENERAL TIPS ON THE USE OF THE G10 drill.

Some general remarks/tips on the use of the G10 drill.



A field can be planted 2 or 3 times in different directions in order to obtain a higher seeding density.



Do not make sharp turns, always drive in straight lines to avoid damaging the machine.



When hitting a hard object in the soil, the cutting elements may be burred/damaged.



Try to file burrs away or replace the cutting element.



When the cutting elements become wet, the seed may stick and accumulate between the cutting elements.



**NEVER** drive backwards while the running wheel is on the ground.



Set the drill down gently when planting. Slamming it down hard can cause damage to the machine. The speed should be controlled by the hydraulic setting on the tractor.

## 9.0 OPERATING THE G10 NO TILL DRILL

Before using the G10 drill in the field, check the following:



1. Are there any loose objects in the field? Remove these first.



2. Are there any slopes? The maximum slope this machine can work on is 20 degrees. Always work downhill.



3. Does the ground contain hard objects? If so, use the G10 drill at a low speed and adjust the working depth.



4. Is there any danger of flying objects, which may distract the attention of the driver? If so, do **NOT** use the G10 drill.



5. Is there any danger of sinking or sliding away? If so, postpone the work.

6. If the soil is frozen or very wet, the work should be postponed until the conditions are more favorable.



## 10.0 STARTING/STOPPING PROCEDURE

Before starting the seeding, check the machine for the following points:



**While checking the machine/tractor combination must be fully locked to prevent it from driving/sliding/sinking away. The tractor engine must be switched off.**

- Check the seeding elements for damage and repair if necessary.
- Check if the passage to the seeding elements is not blocked (e.g. funnels).
- Check if the machine is not wet or moist, in particular the seeding device.
- Check the seed spreading by rotating the running wheel 1 time (counterclockwise).
- Check if the drive is running smoothly.

### START SEEDING.

The starting procedure is VERY important. If this procedure is not followed exactly as described below, serious damage may occur to the machine. The procedure is as follows:

1. Put the seed in the seed hopper.
2. Set the required seed quantity. (see section 5.0).
3. Set the right working depth. (see chapter 4.0)



**While adjusting, the machine/tractor combination must be fully locked to prevent it from driving/sliding/sinking away. The tractor engine must be switched off.**

4. Drive to the place where you want to start.
5. While driving lower the machine carefully and in a controlled way until the seeding elements are cutting the ground.
6. Increase the speed until the correct driving speed has been reached.

### STOP SEEDING

1. While driving, raise the machine out of the ground.
2. Go to the following place and start again as described.
3. When the seeding has been completed the seed element valve (Figure ) must be closed. Seeds will spill out unintentionally when the valve remains open while driving.



It is absolutely imperative that the above procedures are followed. If the machine is placed in the ground while standing still, it may be seriously damaged.



During the lowering process lower the machine **CAREFULLY AND IN A CONTROLLED WAY.**



**NEVER** drive backwards when the machine is on the ground.

## 11.0 DISCONNECTING THE G10 No Till Drill

The machine can be disconnected from the tractor as follows (see Figure 7).

1. Drive the G10 drill to a storage place with a stable/even floor.
  - ⚠ **Make sure the tractor is secured in place and cannot start moving**
  - ⚠ **Turn the tractor off before dismounting**
  - ⚠ **Be sure that the G10 drill is stable on the floor and can't move unintentionally before dismounting the tractor**
2. Lower the legs (5) downwards and lock them using the locking pins included.
3. Slowly lower the machine until it stands on the ground.
4. Loosen the top link (3) and remove it.
5. Disconnect the lower arms (4) from the G10 drill.
6. Empty seed hopper and elements of all seed. Mice love seed!
  - ⚠ **To avoid damage to the machine make sure that the cutting elements do not touch the ground when storing the machine.**

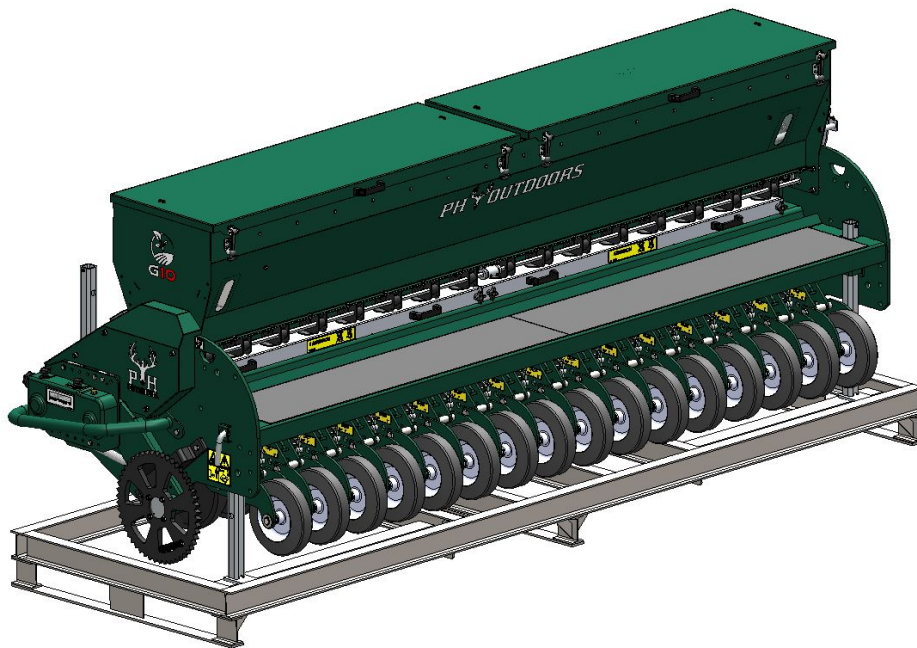

## 12.0 TROUBLESHOOTING

Problem	Possible cause	Solution
Seeding slits are not deep as desired	Seeding discs are worn	Replace the seeding discs.
	Soil conditions are too hard. Check depth settings	Prepare the ground if it is too hard Wait for rain dry better weather Change settings
	Top link incorrectly adjusted.	Correctly adjust the link.
Seeding disks don't turn / stuck		Apply optional coultter knife kit.
	Bearings too tight	Loosen the disks.
		Replace bearings.
Seeding cuts are not closed.	Slits are too wide.	Reduce the working depth.
	Packing wheel not on the ground	
	Worn seeding discs.	Replace the seeding discs.
The seed is not in the ground	Wrong working depth.	Adjust the machine to correct depth.
	Seeding funnel blocked.	Unblock/clean.
	Too wet conditions.	Postpone the seeding.
	Seeding valve too open.	Close the valve.
	Driving too fast	Slow down to match soil conditions.
Seed is spilled from the seed tray.	Tractor tensioning is too low.	Put drawing arms into a higher hole.
The machine does not reach the required depth.	Top link is incorrectly adjusted.	Correctly adjust the top rod.
	Too much vegetation	Apply optional Coultter knife kit (Chapter 15)

Tabel 2

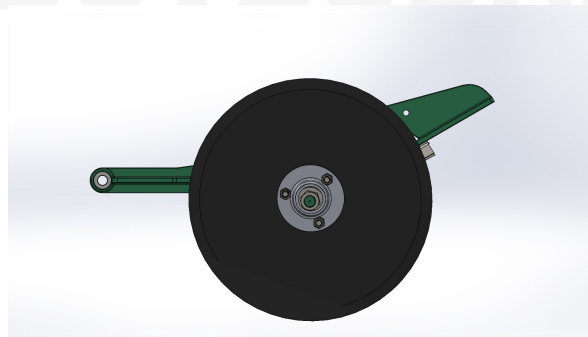

Remember when changing the cutting discs that one side has RIGHT HAND THREADS and the other is LEFT HAND THREADS

## 13.0 MAINTENANCE

Time schedule	Check point/lubricating point	Method
Before <b>each</b> use	Check for loose bolts/nuts. Check for loose D-Shackles.	Tighten the loose bolts/nuts with the correct torque.
	Presence and legibility of safety stickers (Figure 5)	Replace if damaged or missing.
After <b>each</b> use	Clean the machine Check for loose bolts/nuts. Check for loose D-Shackles	Clean the machine with compressed air. Don't use water.
After <b>first</b> 20 operating hours (new or repaired)	Grease the wheel bearings of the rear wheels.	Use EP 2 lubricating grease.
	Check for loose bolts/nuts Check for loose D-Shackles.	Tighten the loose bolts/nuts with the correct torque.
	Grease the drive chains.	Use a chain spray.
After <b>every</b> 100 operating hours.	Check for loose bolts/nuts Check for loose D-shackles.	Tighten the loose bolts/nuts with the correct torque.
	Grease the drive chains.	Use a chain spray.
	Check the tension of the drive chains.	Tension the tensioners of the drive chains.
	Check the seeding elements for dirt/damage.	Clean the seeding elements or replace if necessary.
	Check the seeding element valve opening.	Adjust the seeding element valve if necessary.
	Check the seed quantity.	Carry out a spreading test.
	Check the seeding pipes/funnels.	Clean if necessary.
	Grease the wheel bearings of the rear wheels.	Use EP 2 lubricating grease.
	Make sure there is enough gear oil in the gearbox	Fill the gearbox with SAE 80 gear lube
	Clean the hopper	Clean with compressor air, don't use water.

Table 3

### 13.1 TECHNICAL INFORMATION: DIGITAL SURFACE METER

The machine can be equipped with a digital surface meter that can be used to read various data such as the machined area, distances, hours of work, etc.

For the explanation of the operation of this surface meter, a manual is included in the toolbox.

If the settings of the surface meter have disappeared from memory, these are the specific parameters to be filled in:

Machine	Parameter "C" Pulses of the speed sensor (Chapter 8.2)	Parameter "L" Working width (Chapter 8.4)
<b>PH Outdoors G-Series</b>	Setting UN=1	
G10 drill	79	10.0



If the gearbox hasn't been leaking it doesn't need oil added in most situations

## 13.2 GREASE POINTS

For grease points on the machine, see (Figure 13). There are grease points on the rear wheels of the machine and a chain behind the cover on the side of the machine. Check Table 3 for maintenance intervals.

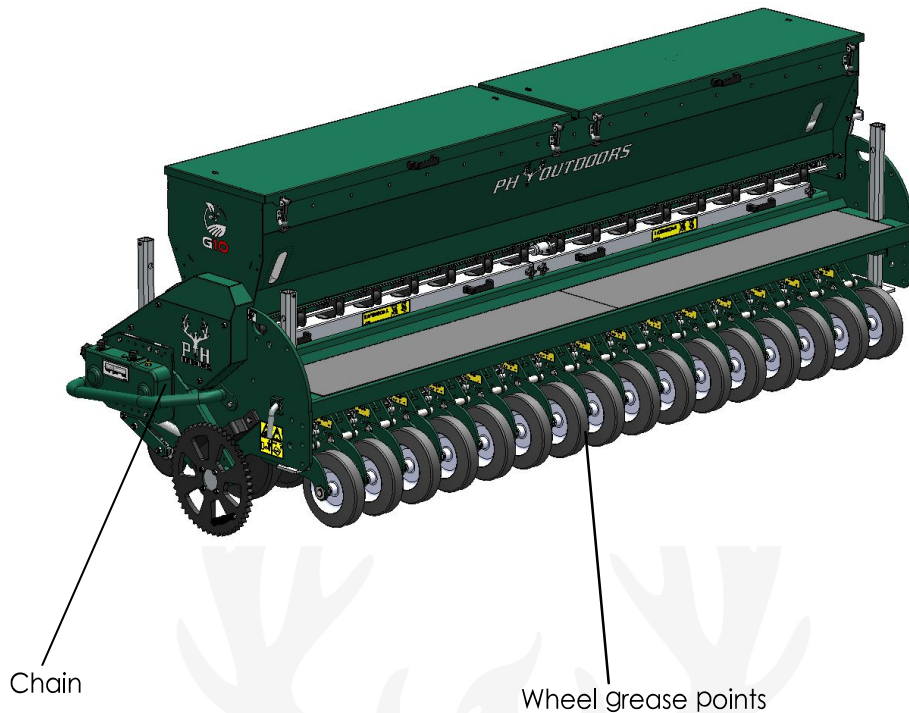

Figure 13

## 14.0 ADJUSTING THE SPRING TENSION OF THE SIDE WHEEL

When the seeding wheel (3) is slipping it is possible to adjust the wheel pressure on the ground by changing the spring (2) position. (see Figure 14)

Place bolt and nut (1) in another hole to enlarge the preload of the spring (2).

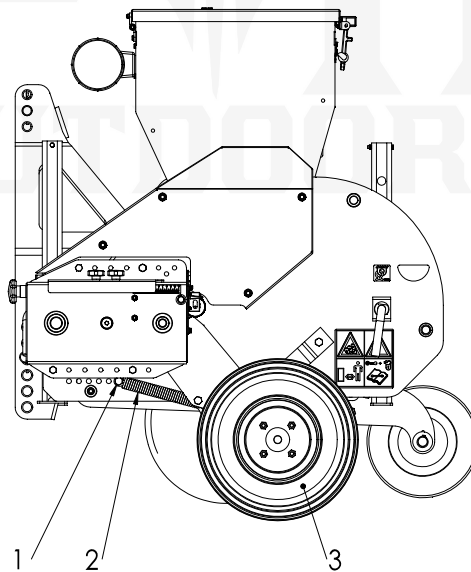

Figure 14

## 15.0 OPTIONAL EXTRAS: TOWING KIT

If the tractor is not able to lift the G10 drill, the machine can be equipped with a tow kit. This makes it possible to lift and move the G10 drill with a lighter tractor or utility vehicle. The following Tow Kit is available:

The kit contains cylinders, drawbar, wheels/tires, hydraulic hoses, brackets, rods + rings and fixing material consisting of a number of bolts and nuts. (Figure 16)

Mounting the parts of a boggy kit, proceed as follows:

1. Mount the wheel (1) on the frame with the supplied bolts and nuts.
2. Mount the cylinders (2) on both sides of the frame with the supplied bolt and nuts.
3. At the front of the machine must be mounted the draw bar (4). Which can be mounted by fastening it with standard fixing pins at the lower 3-point plates.
4. Install the top link (5) with two pins (6) and R-clips on draw bar (4) and top link.
5. Place the various hydraulic couplings (7) and hoses (8).
6. See parts pages for exact position and sequence hydraulic components.

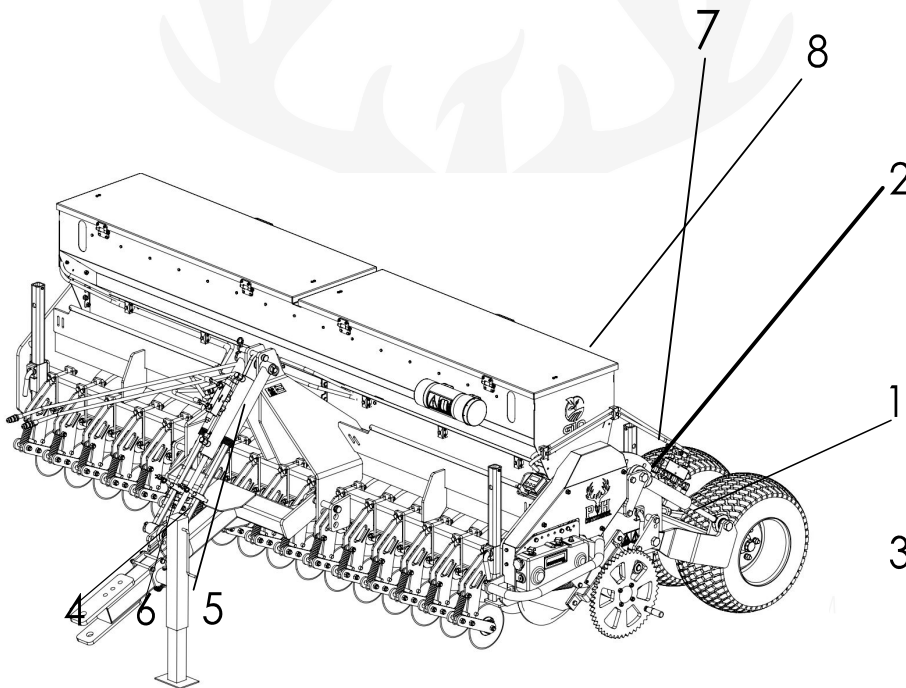

Figure 16

**⚠ NEVER CRAWL UNDER THE MACHINE**

**⚠ MAKE SURE THE MACHINE IS SECURELY PLACED**





UC 300

UNIVERSAL COUNTER



NR.1111-EN

USER'S MANUAL





This product complies with EMC requirements as defined by Directives 2004/108/CE and successive modifications in accordance with standard EN ISO 14982 applied

**Manufacturer** : MC elettronica S.r.l.  
**Address** : Via E. Fermi, 450/486  
Fiesso Umbertiano (ROVIGO) – ITALY  
Tel. +39 0425 754713 Fax +39 0425 741130  
E-mail: [mcstaff@mcelettronica.it](mailto:mcstaff@mcelettronica.it)  
Internet: [www.mcelettronica.it](http://www.mcelettronica.it)

**Manual code** : 1111-EN  
**Issued** : November 2011  
**Edition** : April 2014



**MC elettronica S.r.l.** is not obliged to give notice of any further modifications of the product.  
The information given in this manual does not allow unauthorized personnel to tamper the product in any way. The guarantee on the equipment will no longer be valid if tampering should be detected.



## **Content**

<b>1. Rules and general warning</b> .....	<b>4</b>
1.1 Introduction .....	4
1.2 Terms of guarantee .....	5
1.3 Service .....	5
<b>2. General description</b> .....	<b>6</b>
<b>3. Description of the panel and electrical connections</b> .....	<b>7</b>
<b>4. Overall dimensions</b> .....	<b>8</b>
<b>5. Operation</b> .....	<b>9</b>
<b>6. Low battery warning</b> .....	<b>9</b>
<b>7. Standby mode</b> .....	<b>10</b>
<b>8. Programming</b> .....	<b>10</b>
8.1 Programming the “Un” (unit of measurement) parameter .....	11
8.2 Manual programming of parameter “C” (pulses of the speed sensor) .....	11
8.3 Automatic programming of parameter “C” (pulses of the speed sensor) .....	12
8.4 Programming parameter “L” (working width) .....	13
<b>9. Maintenance</b> .....	<b>14</b>
9.1 Ordinary maintenance .....	14
9.1.1 How to protect the main connector .....	14
9.2 Extraordinary maintenance .....	14
<b>10. Technical data</b> .....	<b>15</b>

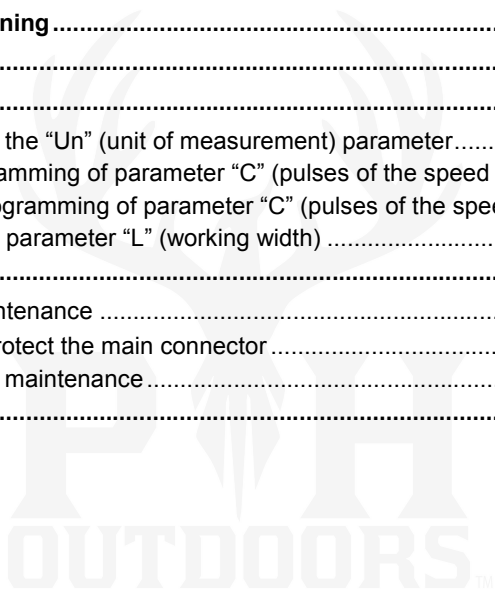

# 1. Rules and general warning

## 1.1 Introduction

This manual gives all the specific information that you need for a proper use of the equipment.

After buying the instrument, read the manual carefully and refer to it any time you have doubts on how to use the equipment or when you have to carry out maintenance operations.

Keep the manual on the machine. If this is not possible, keep it ready to hand.

ALL RIGHTS RESERVED. THIS MANUAL IS INTENDED FOR CUSTOMERS ONLY. ANY OTHER USE IS FORBIDDEN.



## 1.2 Terms of guarantee

**SUBJECT OF THE GUARANTEE:** the guarantee is applied to the product and to those parts which are marked with the serial number or any other identification number used by *MC elettronica*;

**HOW LONG THE GUARANTEE IS EFFECTIVE:** *MC elettronica S.r.l.*

guarantees the UC 300 for a period of **1 year** from the manufacturing date (printed on the identification label which is to be found on the rear side of the equipment) and also accessories.

The guarantee covers the product and any repair carried out within the agreed terms.

This guarantee does not apply in the event of:

accidental damage;

improper use;

modifications which haven't been agreed upon, improper installation (or setting);

damage caused when a non-*MC elettronica* equipment, which is mechanically or electrically connected to our instruments, breaks or does not function properly;

act of God (lightning, floods, fire or other causes which do not depend from *MC elettronica*).

Repairs under guarantee, which must be carried out in the laboratories of our authorized centres, are entirely free of charge provided the equipment is directly transported to said laboratories or sent free port. Transport charges and risks are entirely borne by the Customer.

The above-mentioned guarantee is valid unless otherwise stated between *MC elettronica* and the Customer.



### **Warning**

*Mc elettronica* declines any liability for damages or direct or indirect charges, as a consequence of improper use or inability of the Customer to use the equipment separately and/or together with other instruments.

## 1.3 Service

Service is available in all the countries where the equipment is officially supplied by *MC elettronica* (during and after the guarantee period).

Any kind of operation that is to be carried out on the UC 300 must be done in accordance with the instructions stated in this manual or as agreed with *MC elettronica*. If not, the relative terms of guarantee might become void.

## 2. General description

The UC 300 Universal Counter is powered by a rechargeable battery and stores all the main functions of a hectare counter in a small container which can be installed easily on any public works vehicle. You can choose between metric and imperial units of measurement to calculate area, distance and speed. The UC 300 Universal Counter can also count the working hours when the machine is running. Displayed on the screen are:

- 1) independent total counter for surface area (in hectares or acres, in units of 10 m<sup>2</sup> or 0.001 acres)
- 2) independent partial counter for surface area (in hectares or acres, in units of 10 m<sup>2</sup> or 0.001 acres)
- 3) speed of travel (in km/h or mph, in units of 0.1 km/h or 0.1 mph)
- 4) counter of distance covered (in metres or feet, in units of 1 metre or 1 foot)
- 5) working hour counter (in units of 0.1 hours)

Provided with the UC 300 are a battery charging cable, a magnetic sensor and a magnet of reference: the code for the complete kit is 00KIT-0014;

When the battery is running low, this is signalled on the display (refer to the section "Operation"). The user can connect the charging cable to the battery of the tractor and continue working during the charging process, or disconnect the sensor and charge the monitor separately.

Inside the connector of the magnetic sensor is a jumper for powering the UC 300: disconnecting the sensor turns off the monitor, saving on battery power. PLEASE NOTE: it is advisable to disconnect the sensor only when the machine is at standstill to avoid the partial loss of data of the totalizes; the programmable parameters, however, remain saved.

Essential requirements for the Universal counter:

- a) Powered by 3.6V internal rechargeable batteries
- b) Nominal battery charge voltage: 12V (16V max)
- c) Maximum dimensions: 78 mm in width, 78 mm in height and 38 mm in depth.
- d) 5-digit display + indicators, not backlit
- e) External application (IP66).

### 3. Description of the panel and electrical connections



Rif.	Description	signal Type INput/OUTput	Pin connector S.SEAL 4-way
A	LCD Display:		
	A1-A5: arrows indicating the size selected A6: arrow indicating low battery	-	-
B	Selection key size and "-" in programming	-	-
C	Programming key: allows you to enter the phase of programming parameters	-	-
D	Selection key size and "-" in programming	-	-
	Input magnetic sensor (*)	IN NPN NO	4
	Mass for the magnetic sensor	OUT GND	1
	Pin for bridge power monitor	-	2 e 3

(\*) = Maximum input frequency 35Hz magnetic sensor

## 4. Overall dimensions

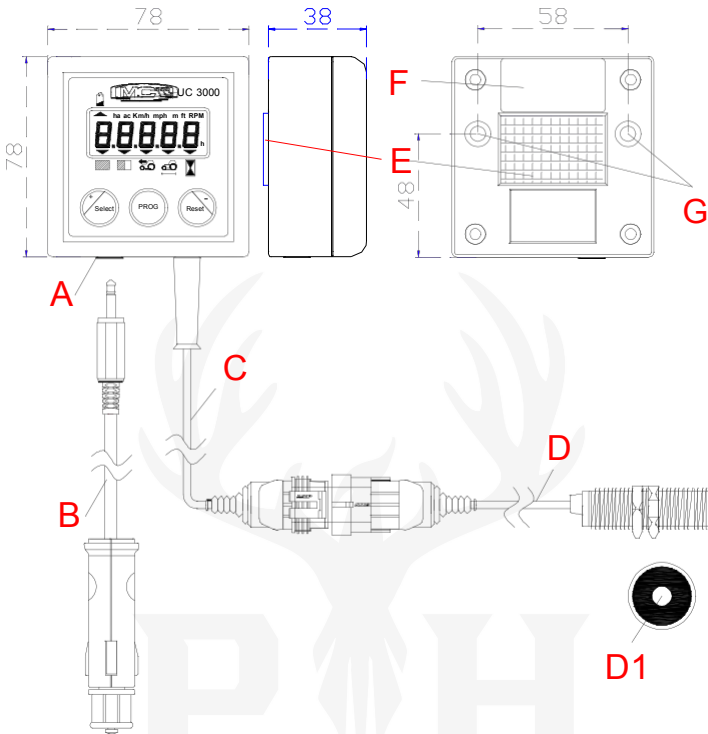

<b>A</b>	3.5 jack connector panel for battery charging
<b>B</b>	Cable 50 cm with cigarette lighter plug for charging battery (supplied) cod. CAV-0017
<b>C</b>	cable 20 cm with conn. s.seal 4-way for connection the magnetic sensor
<b>D</b>	sens. magnetic supplied cable and magnet diam.20mm (D1)
<b>E</b>	3M DUAL LOCK for removable mechanical attachment
<b>F</b>	label with identification parameters
<b>G</b>	M5 threaded inserts for mechanical fixing to panel

## 5. Operation

When the counter is started up for the first time (or after the battery is charged after having run down completely), the total area counter is shown on the display. The UC 300 is set by default to show metric measurements: the area is given in hectares, the speed in km/h and the distance covered in metres. The initial sequence is, therefore: Pressing the “select” button during operation shows the next measurement on the display, as follows

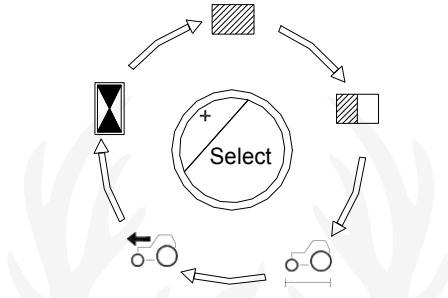

After selecting a measurement it is possible to reset it by pressing and holding the "reset" button for 3 seconds (with the exception of the speed of travel, which is instantaneous data).

## 6. Low battery warning

When the battery is nearly run down, the arrow under the battery symbol in the top left-hand corner lights up;

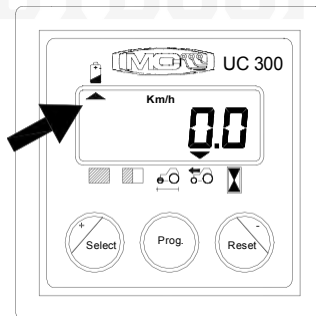

the residual autonomy of the UC 300 before it turns off completely is limited and will depend also on use. If the battery runs down completely and the UC 300 turns off, some of the data may be lost (refer to the previous section); to charge the battery, connect the cable with the jack connector (provided) to a 12V battery: **Do NOT use car battery charging devices.** The charging process generally takes about 10 hours, while the autonomy between a charging cycle and the next is about 2.5 years (although this depends on the extent and conditions of use); it is not necessary for the speed sensor to be connected while the battery is charging.

## 7. Standby mode

To save on energy and increase the autonomy of the batteries, the UC 300 automatically goes into standby after 5 minutes if it does not receive any pulses from the speed sensor and none of the buttons are pressed. In standby mode, power consumption is less than 30 $\mu$ A and the last data remains on the display without any other information. The UC 300 exits standby mode when the next pulse is received from the speed sensor or when you press any button for at least 1 second.

## 8. Programming

As with the totalizers, either metric or imperial units of measurement can be used for the programmable speed and area parameters. To access the programming phase with the UC 300 turned on, press the “Prog” button for 3 seconds and five horizontal dashes appear on the display. The first programmable parameter, “Un”, then appears as shown below;

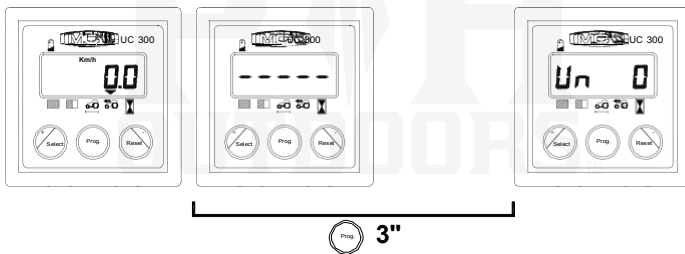

During the programming phase, you can use the “+” and “-” buttons to edit the value of the parameter, then press the “Prog” button to confirm your changes and move on to the next parameter;



## 8.1 Programming the “Un” (unit of measurement) parameter

Programming of this parameter is very important to the work in hand and to the programmable parameters. You need to select either the metric or imperial unit of measurement; you then only need to program the parameters of the UC 300 for the chosen unit of measurement.

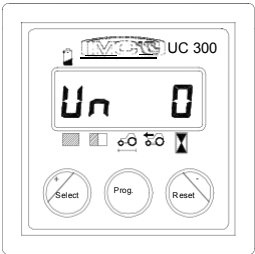
	Name of parameter:	Un
	Description:	selection of unit of measurement
	Programmable range:	0 (=metric units) or 1 (=imperial units)
	Default value:	0

## 8.2 Manual programming of parameter “C” (pulses of the speed sensor)

This parameter represents the number of pulses emitted by the speed sensor after each 100 linear metres (or 328 feet) covered by the public works machine;

Enter the programming phase as described above and edit the value with the “+” and “-” buttons; pressing and holding either button will speed up the editing process. After setting the required value, press “Prog” to confirm and move on to the next parameter.

with “Un” = 0 	Name of parameter:	C
	Description:	Pulses of the speed sensor after every 100m covered by the machine
	Programmable range:	20 to 999 Steps of 1 pulse
	Default value:	200

<p>with "Un" = 1</p> 	Name of parameter:	C
	Description:	Pulses of the speed sensor after every 330 feet covered by the machine
	Programmable range:	20 to 999 Steps of 1 pulse
	Default value:	200

### 8.3 Automatic programming of parameter "C" (pulses of the speed sensor)

It is possible to program parameter C automatically: after entering the programming phase as instructed above, and with "C" shown on the display followed by the value currently programmed, press both the "+" and "-" buttons at the same time and the following appears on the display

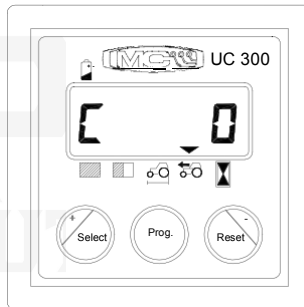



At this point, travel 100 metres (or 330 feet) in the machine and the number will increase automatically on the display. After covering this distance, press the "Prog" button to confirm the data. It is advisable to repeat this operation at least twice.

If you try to acquire a value of less than 20 pulses, "Err" appears on the display and the UC 300 retains the last valid value to have been saved.

### 8.4 Programming parameter “L” (working width)

This parameter is the working width of the machine in metres (or feet).

Enter the programming phase as described above and edit the value with the “+” and “-” buttons; pressing and holding either button will speed up the editing process. After setting the required value, press “Prog” to confirm and exit the programming phase.

<p>with “Un” = 0</p> 	Name of parameter:	L
	Description:	Working width in metres
	Programmable range:	00.10 to 30.00 Steps of 0.01m
	Default value:	1.50
<p>with “Un” = 1</p> 	Name of parameter:	L
	Description:	Working width in feet
	Programmable range:	00.32 to 98.40 Steps of 0.01 feet
	Default value:	4.92

## 9. Maintenance

This chapter gives instructions on how to carry out ordinary and extraordinary maintenance.

**Ordinary maintenance** refers to those operations which must be carried out periodically. As they do not require specific skills, they can be carried out by the users (operators etc.).

**Extraordinary maintenance** refers to unforeseeable operations due to mechanic or electric failures. They require specific technical skills, so they should be exclusively carried out by qualified personnel (maintenance personnel etc.).

### 9.1 Ordinary maintenance

Ordinary maintenance consists in cleaning the instrument. Clean the instrument with a wet cloth and mild detergent to avoid erasing the serigraphs on the panel.



**Warning**

*Do not use pressure water jets.*

*Do not use abrasive products, solvents or alcohol.*

*Do not press on the keyboard with pointed or hard objects in order to avoid damaging the polyester film, thus endangering the impermeability of the keyboard.*

#### 9.1.1 How to protect the main connector

In case of an extended use of the Monitor it is advisable to disconnect the main signal connector from the harness. It is advisable to insulate both the connectors (of the Monitor and of the Harness) by using a Nylon protection.

If the connectors of the monitor and of the harness are NOT disconnected no protection is needed.

### 9.2 Extraordinary maintenance



**Warning**

*Extraordinary maintenance must be carried out by authorized personnel only.*

## 10. Technical data

Power supply voltage	3.6 Vdc (internal batteries)
Max. energy consumption in stand by	< 50 $\mu$ A
Protection degree	IP 65
Range of operating temperature	-20 / +70 °C
Range of storage temperature	-25 / +85 °C
Mechanic vibrations resistance	2 g random



**WARNING:** THIS PRODUCT CONTAINS TIN AND LEAD. IT MUST BE DISPOSED OF AT THE END OF ITS LIFE CYCLE AT THE DESIGNATED DISPOSAL FACILITIES OR DELIVERED DIRECTLY TO MC ELETTRONICA SRL (ITALY).

