

PH OUTDOORS™

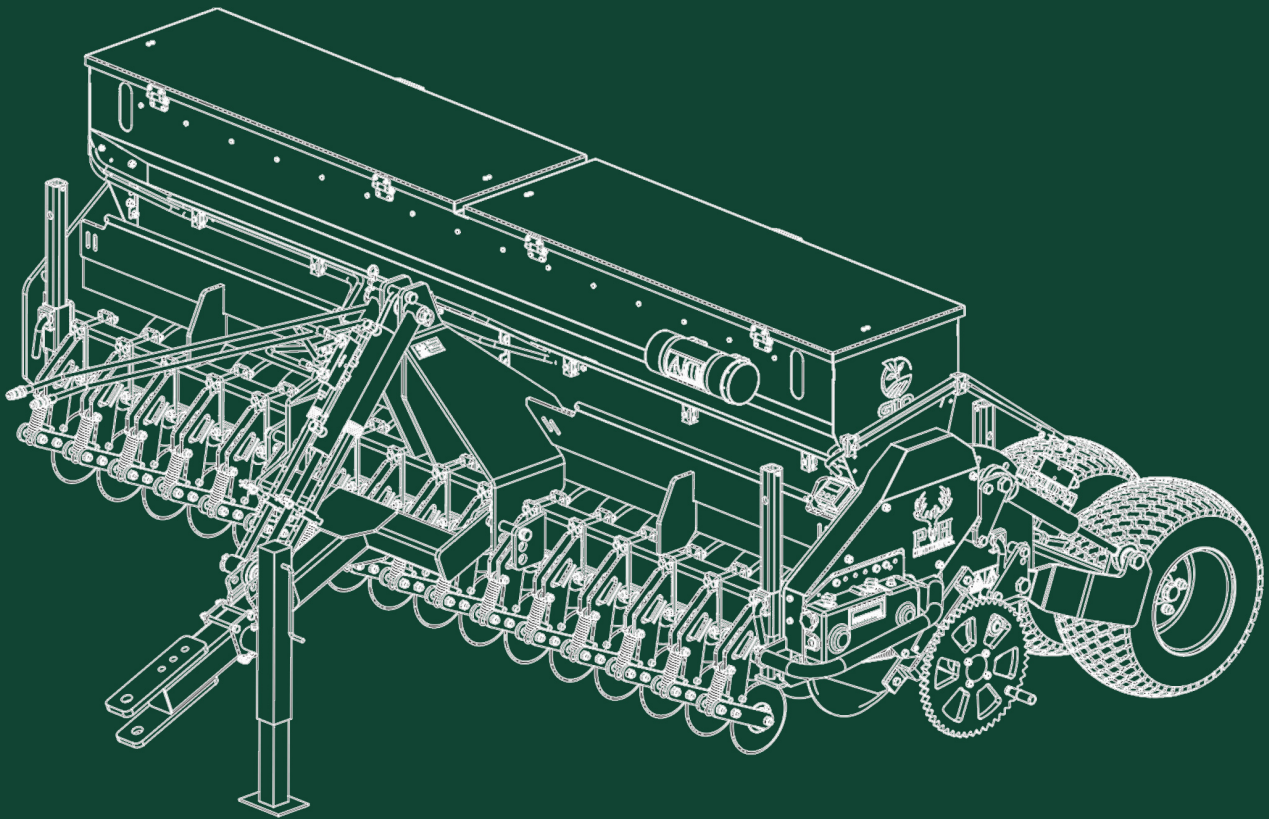

G10 No-Till Drill Original Parts Manual



*Illustrations may include optional items that are not included in standard package

PH Outdoors, LLC

P.O. Box 480
Eureka, MO 63025

**Parts Book
Rev. 1**

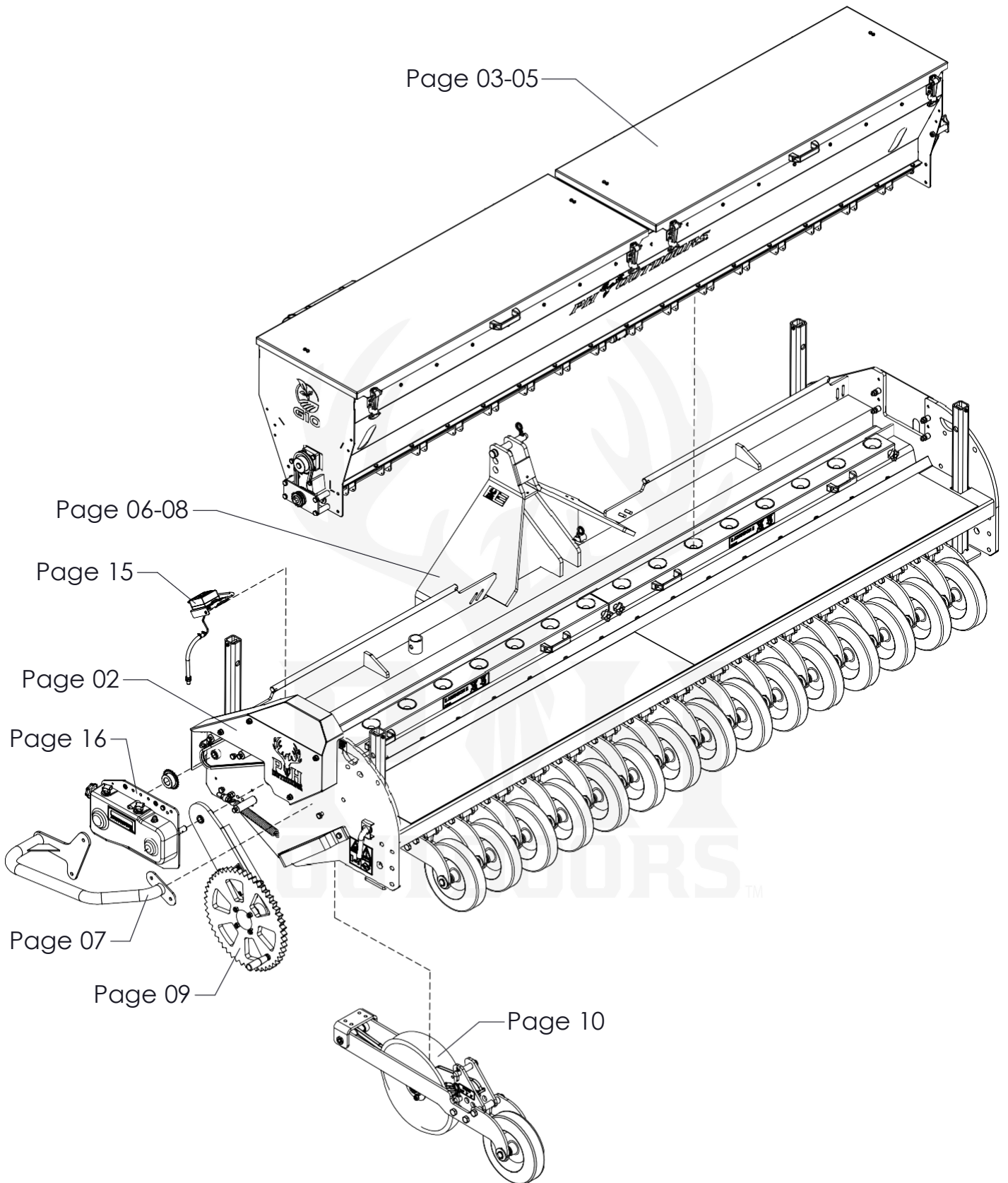

Options:

- Coulter kit : Page 11
- Bogy kit : Page 12
- Hydraulic system kit: Page 13-14

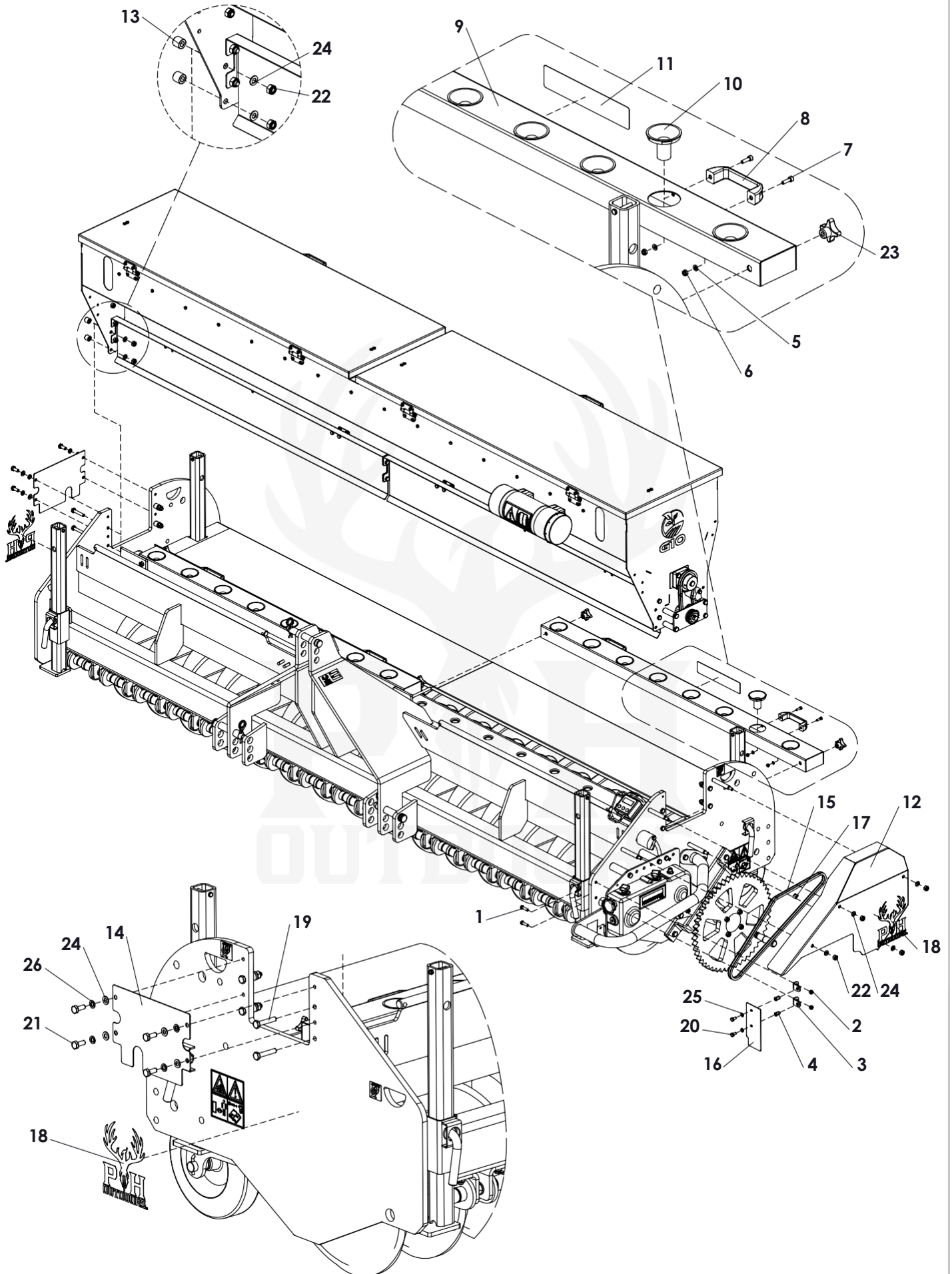

Pos.	Part number	Description	Qty.
1	1008030	Bolt M8 x 30	2
2	1708125	Self-Lock Nut M8	2
3	G500009	Bracket	2
4	1808003	Hexagon Blind Rivet Nut M8	2
5	2210600	Washer M6	8
6	1706100	Self-Lock Nut M6	8
7	1420620	Bolt M6 x 20	8
8	3900002	Handle	4
9	G100003	Funnel frame	2
10	G000029	Funnel	16
11	4010001	Decal funnel	2
12	G000001	Cover G machine	1
13	6010182	Distance bush	8
14	G000002	Cover plate	1
15	3338131	Chain 3/8" 131 shackle	1
16	G500011	Cover plate	1
17	3438000	Chain connector 3_8 inch	1
18	4020007	Label PH Outdoors side	2
19	1110055	Bolt M10 x 55	8
20	1008016	Bolt M8 x 16	2
21	1010025	Bolt M10 x 25	4
22	1710150	Self-Lock Nut M10	12
23	1810001	Knob M10	4
24	2211000	Washer M10	18
25	2211000	Washer M8	2
26	2221000	Spring Washer M10	4

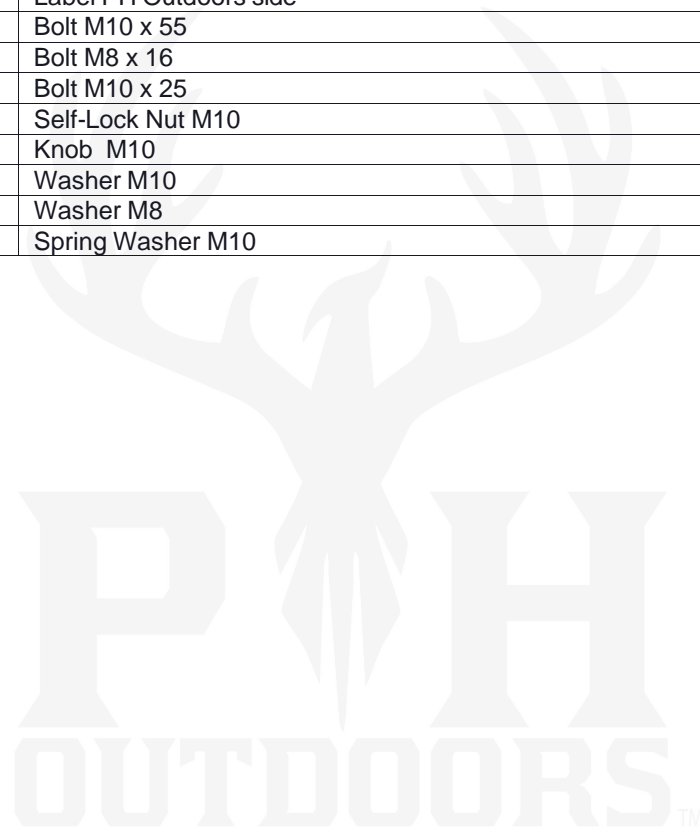

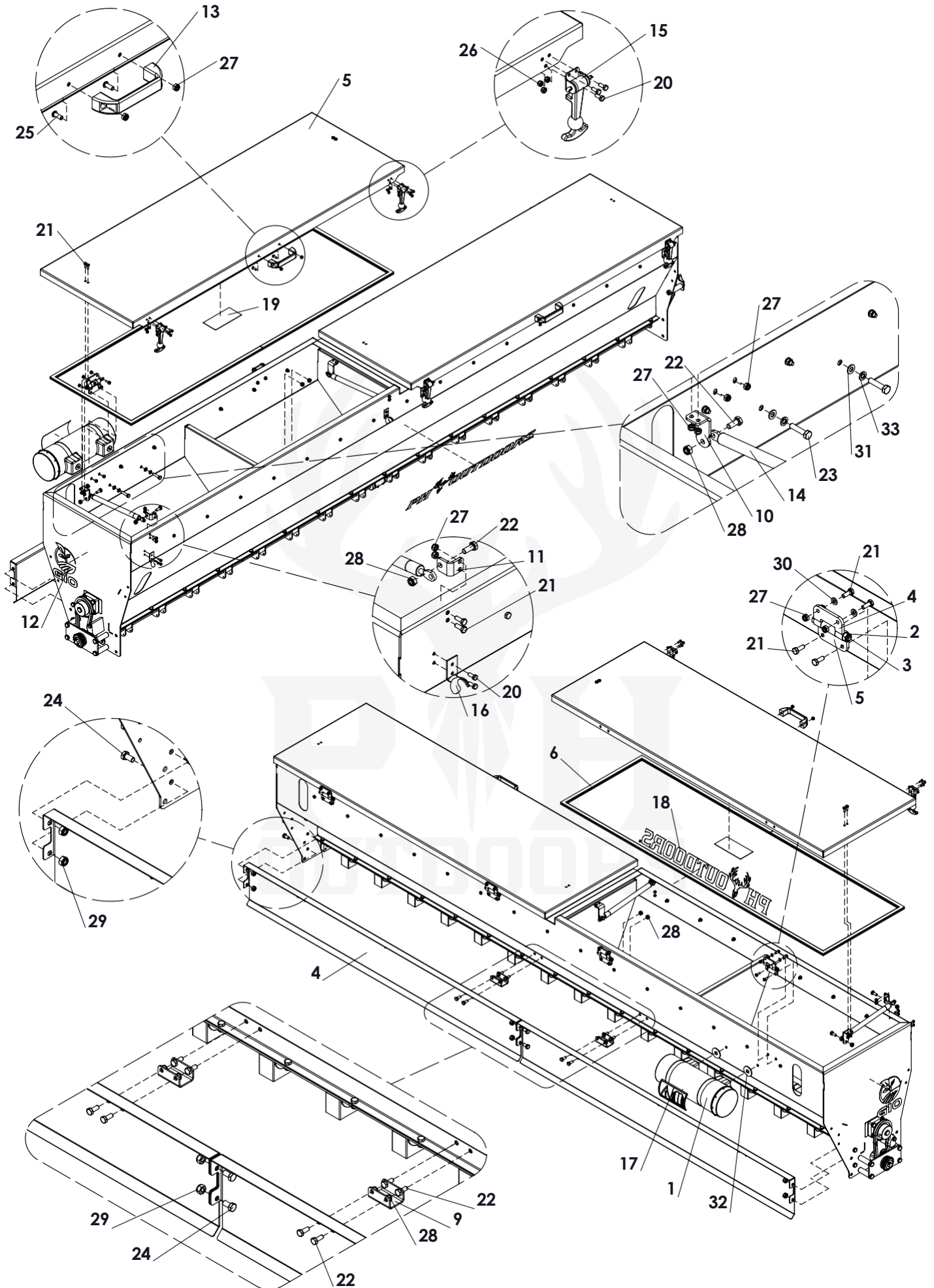

Pos.	Part number	Description	G10
1	3900003	Toolbox assembly	1
2	1708125	Self-Lock Nut M8	4
3	1108075	Bolt M8 x 75	4
4	G000003	Hinge part 1	4
5	G000004	Hinge part 2	4
6	G100049	Rubber U-seal 1-4mm L=3936	2
7	G100050	Cover plate	2
5	G100051	Top cover	2
9	G100052	Support	2
10	G000005	Support L=65mm	4
11	G500028	Support L=30mm	4
12	G100001	Label G10	2
13	3900002	Handle	2
14	G000028	Gas strut L=485/stroke=200, F=150N	4
15	3900005	Rubber lock include hardware	4
16	3900005	Bracket for latch include rubber lock	4
17	4010002	Safety decal manual	1
18	4020000	Label PH Outdoors long	1
19	4020009	Decal seed hopper	2
20	1005012	Bolt M5 x 12	20
21	1006016	Bolt M6 x 16	32
22	1008020	Bolt M8 x 20	12
23	1000835	Bolt M8 x 35	2
24	1010020	Bolt M10 x 20	6
25	2106016	Bolt M6 x 16	4
26	1705080	Self-Lock Nut M5	20
27	1706100	Self-Lock Nut M6	36
28	1708124	Self-Lock Nut M8	12
29	1710150	Self-Lock Nut M10	6
30	2210600	Washer M6	8
31	2210800	Washer M8	2
32	2211401	Large washer M14	2
33	2220800	Spring Washer M8	2



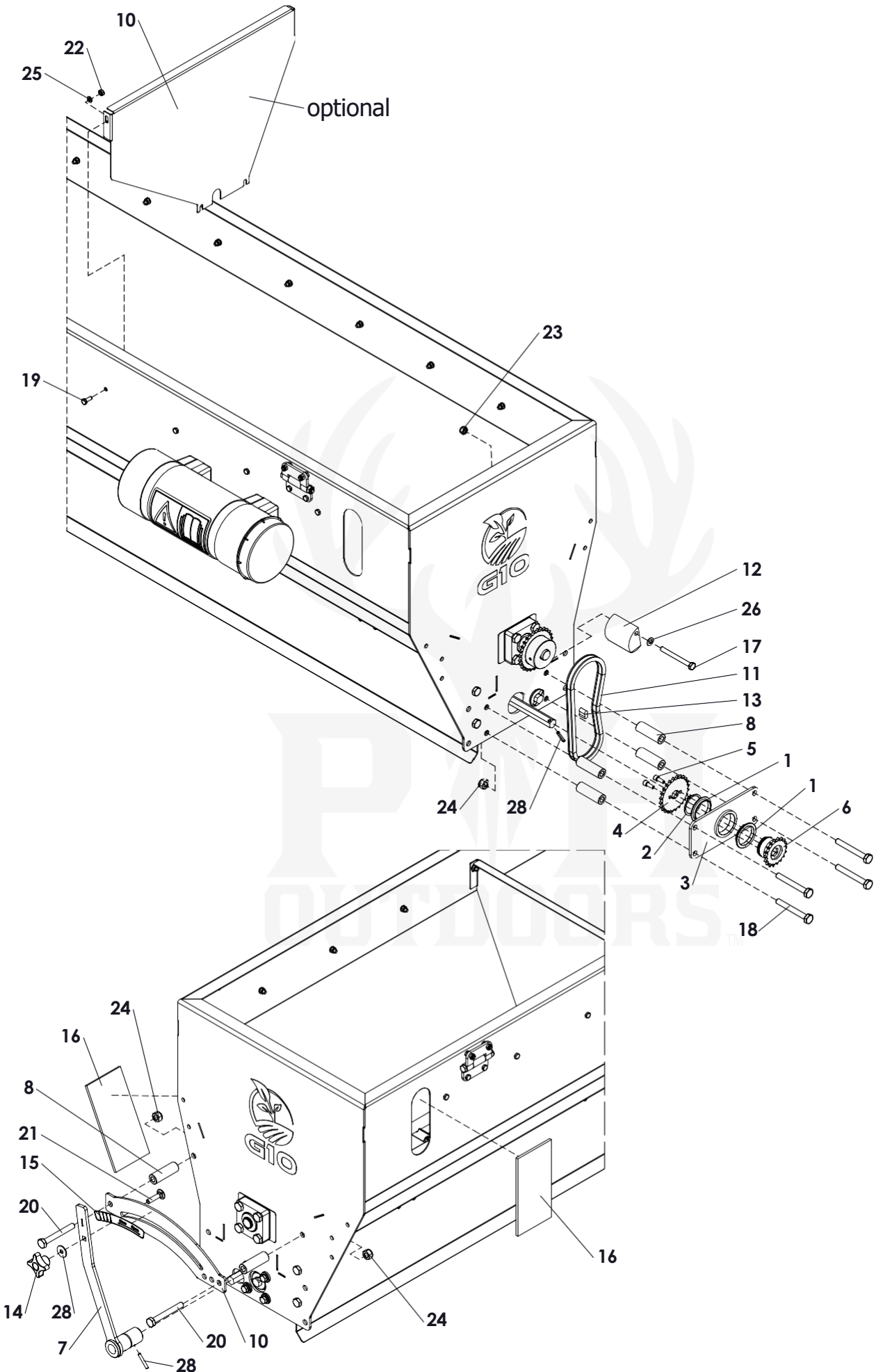

Pos.	Part number	Description	Qty.
1	3240070	Bearing bush	2
2	2614000	Circlip d=40	1
3	G000006	Gear base	1
4	G000007	Sprocket 3/8" (06B) simplex 24Z flat	1
5	4020616	Bolt M6 x 16 - DIN 912	2
6	G000008	Sprocket 3/8"(06B) simplex 18Z special	1
7	G000009	Valve adjustment	1
8	6010060	Distance bush Ø20/Ø10.5 L=60	6
9	G000011	Guide strip	1
10	GDO-02	Divider plate (optional)	15
11	3338063	Chain 3/8" 63 shackle	1
12	G100004	Chain Tensioner	1
13	3438000	Chain connector 3_8 inch	1
14	1808001	Knob M8	1
15	4020005	Decal adjustment valve	1
16	G000027	Window	4
17	1108080	Bolt M8 x 80	1
18	1010080	Bolt M10 x 80	4
19	1006016	Bolt M6 x 16	30
20	1110800	Bolt M10 x 80	2
21	1308035	MH Bolt M8 x 35	1
22	1706100	Self-Lock Nut M6	30
23	1708125	Self-Lock Nut M8	1
24	1710150	Self-Lock Nut M10	6
25	2210600	Washer M6	30
26	2210800	Washer M8	1
27	2211001	Large washer M10	1
28	2405032	Roll pin Ø5x32	2

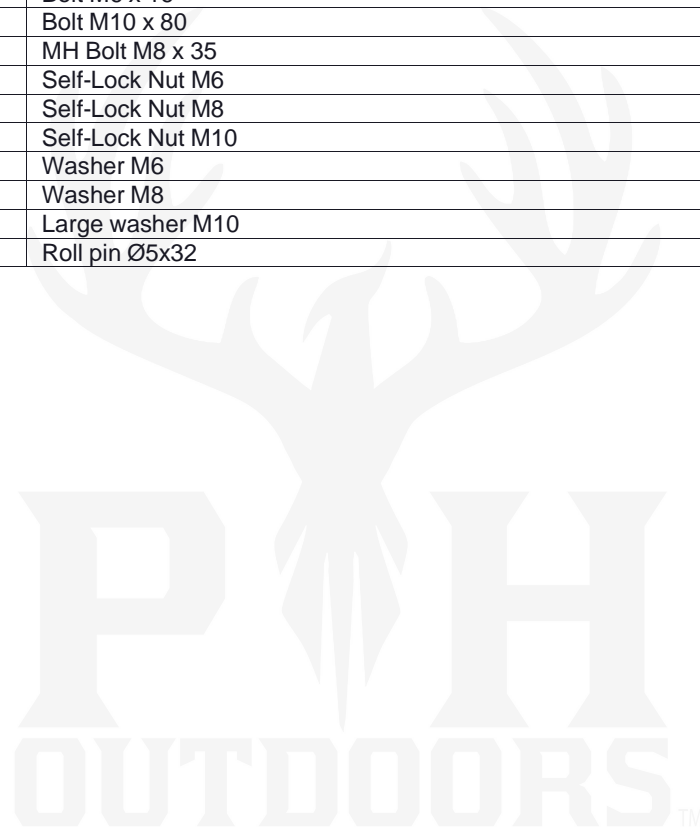

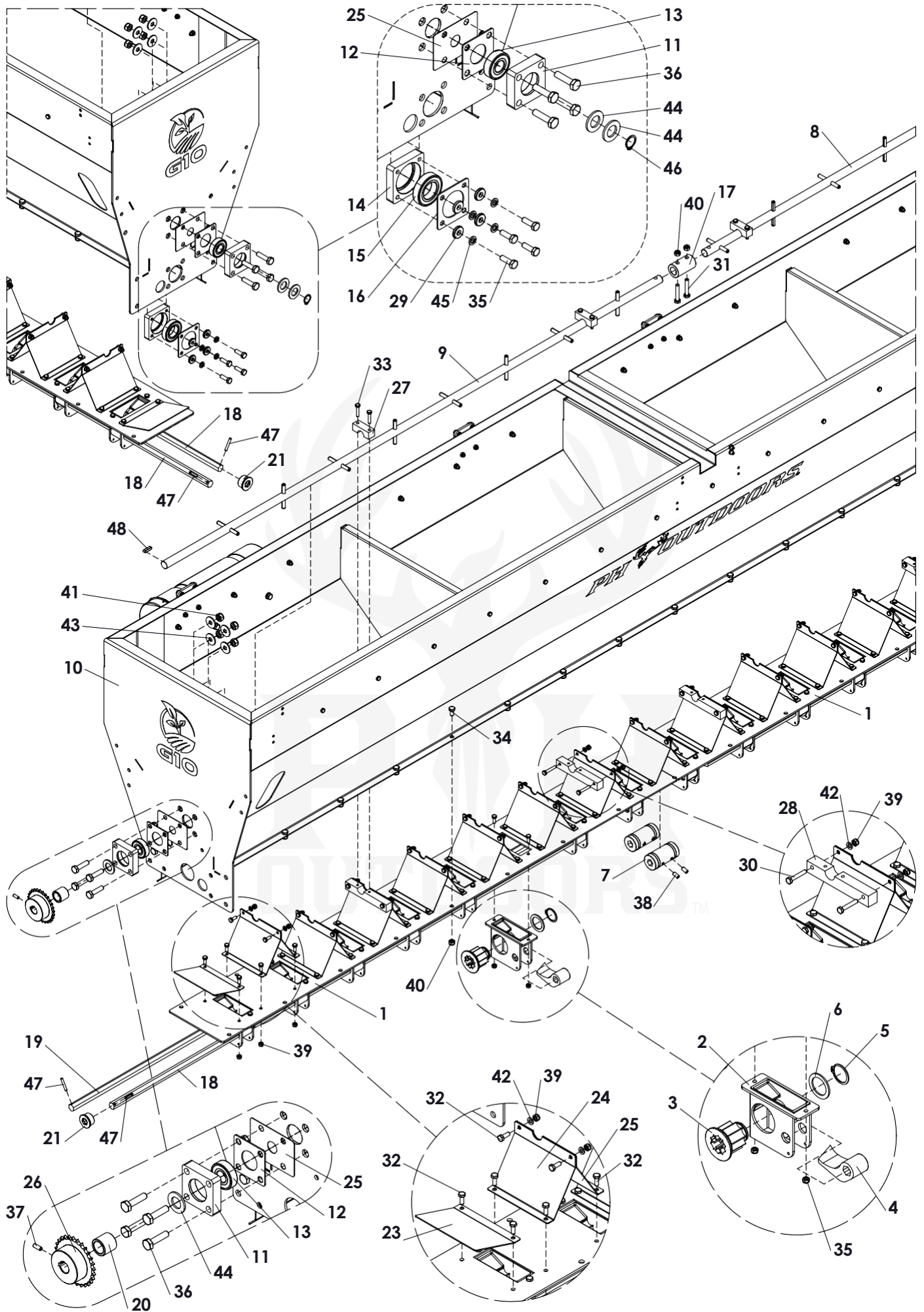

Pos.	Part number	Description	Qty.
1	G100005	Plate	2
2	G000013	Seed element casing	16
3	G000014	Seed element rotor	16
4	G000015	Seed element valve	16
5	2613200	Circlip d=32	16
6	G000016	Washer	16
7	G100002	Coupling bush	2
8	G100006	Agitator shaft	1
9	G100007	Agitator shaft	1
10	G100008	Seed hopper G10	1
11	G000017	Bearing block	2
12	G000018	Cover plate	2
13	2806204	Bearing 6204-C-2HRS	2
14	G000097	Bearing block	1
15	2806006	Bearing 6006 LLU	1
16	G000098	Cover plate large hole	1
17	G100010	Connection bush agitator shaft	1
18	G100011	Hexagon Shaft	3
19	G100012	Hexagon Shaft	1
20	6021017	Distance bush D30/D21 L=27.5	1
21	G000024	Bush	2
22	G000019	Divider side plate	2
23	G000020	Divider plate left	15
24	G000021	Divider plate right	15
25	G000022	Cover plate	2
26	G000023	Sprocket 3/8" (06B) simplex 28Z Ø15	1
27	G100012	Guide Block support	4
28	G100013	Guide Block	4
29	2210801	Washer M8	4
30	1006035	Bolt M6 x 35	8
31	1008045	Bolt M8 x 45	2
32	1006016	Bolt M6 x 16	161
33	1006030	Bolt M6 x 30	8
34	1008016	Bolt M8 x 16	34
35	1008025	Bolt M8 x 25	4
36	1010040	Bolt M10 x 40	8
37	2506016	Set screw M6 x 16	1
38	2508012	Set screw M8 x 12	4
39	1706100	Self-Lock Nut M6	161
40	1708125	Self-Lock Nut M8	53
41	1710150	Self-Lock Nut M10	20
42	2210600	Washer M6	70
43	2211001	Large washer M10	8
44	2212000	Washer M20	3
45	2220800	Spring Washer M8	4
46	2612000	Circlip d=20	1
47	2405032	Roll pin Ø5x32	4
48	4160025	Key 6x6x25	1

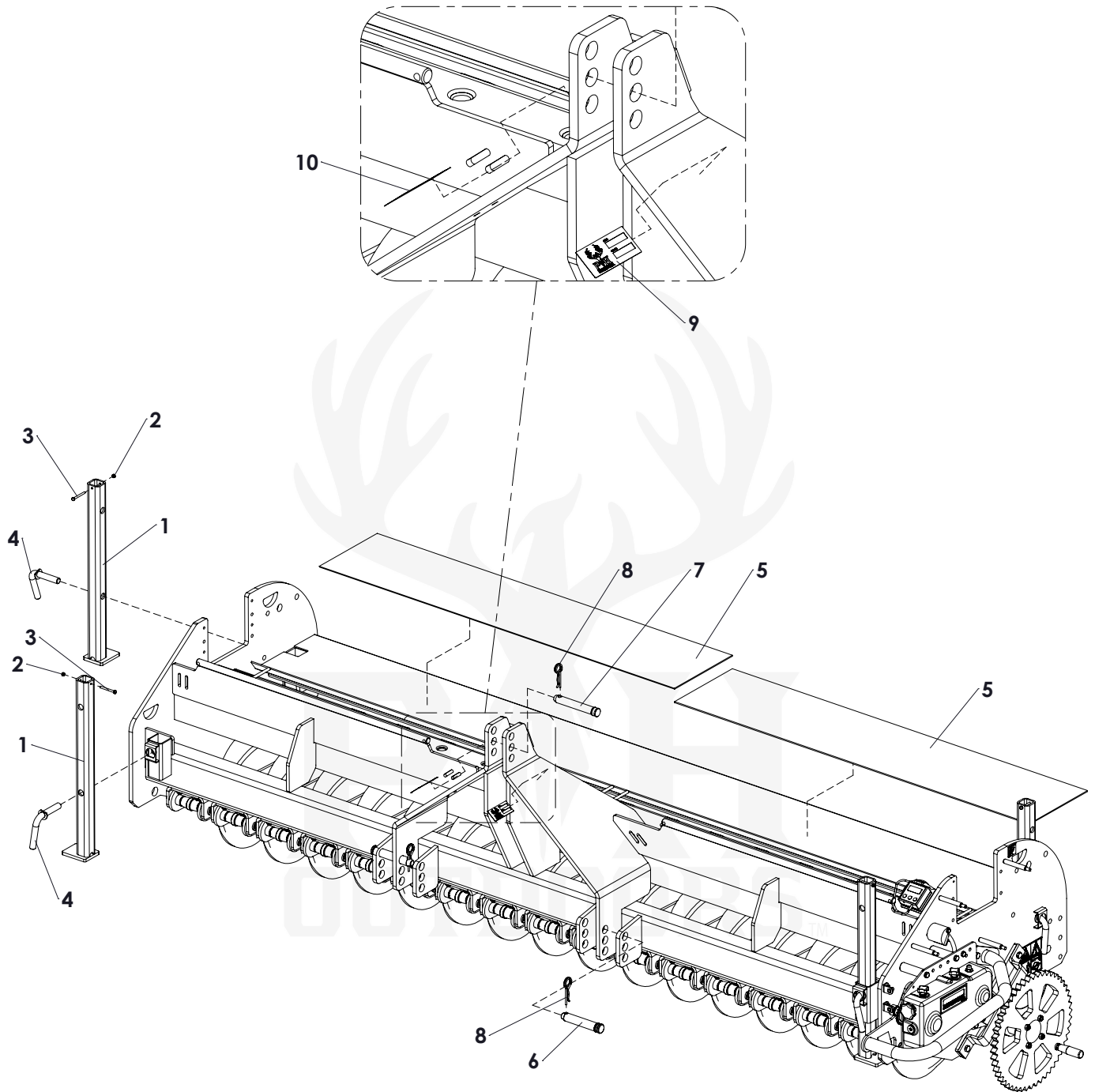

Pos.	Part number	Description	Qty.
1	G000030	Leg assembly	4
2	1706100	Self-Lock Nut M6	4
3	1106060	Bolt M6 x 60	4
4	G000031	Lock pin	4
5	G500022	Rubber grip plate	2
6	3822800	Pin Cat. 2 - 28,6 x 130	2
7	3822500	Top Link Pin Ø25 L=142	1
8	3830500	R-clip Round 5, DIN 11024	3
9	4020006	Serial number label	1
10	4020010	QR code label	1



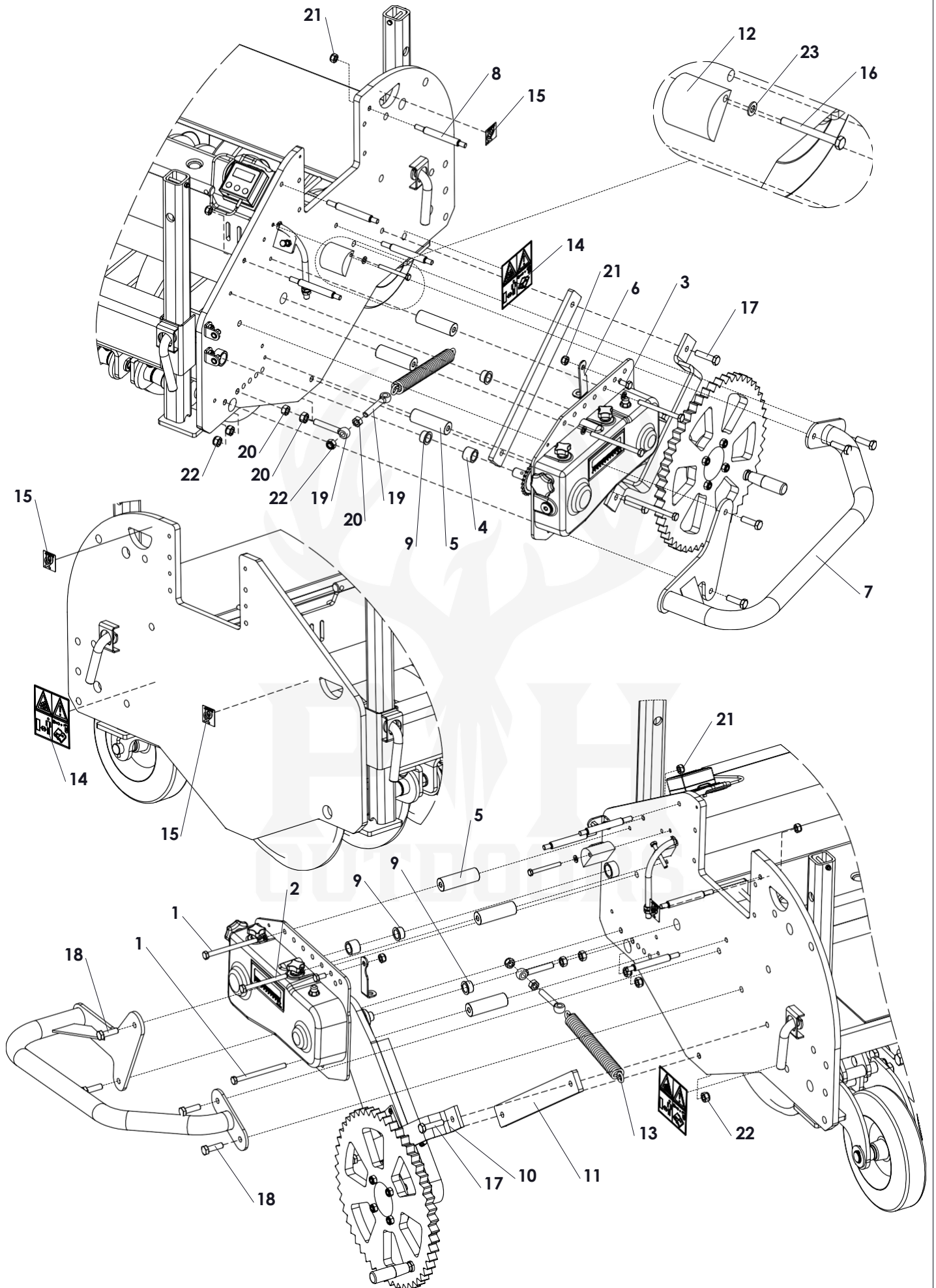

Pos.	Part number	Description	Qty.
1	1110130	Bolt M10 x 130 - ISO 4014	2
2	1110110	Bolt M10 x 110 - ISO 4014	1
3	1010020	Bolt M10 x 20 - ISO 4017	1
4	6021022	Bush	1
5	6010930	Spacer	3
6	G000033	Sensor bracket	1
7	G300031	Gearbox protection	1
8	G000032	Stud Ø15 L=134	4
9	3220150	Bearing bush gear axle	2
10	G500025	Guide swingarm	1
11	G100014	Guide bar side plate	1
12	G100015	Chain Tensioner	1
13	3630250	Spring wheel axle	1
14	4010003	Safety decal	2
15	4020002	Decal fixation point	3
16	1108075	Bolt M8 x 75 - ISO 4014	1
17	1012050	Bolt M12 x 50 10.9	2
18	1012040	Bolt M12 x 40 - ISO 4017	4
19	4212080	Eye Bolt M12x80 DIN 444LB (full thread)	2
20	1801200	Nut M12 - DIN 934	3
21	1710150	Self-Lock Nut M10 - ISO 10511	6
22	1712175	Self-Lock Nut M12	8
23	2210800	Washer M8 - ISO 7089	1



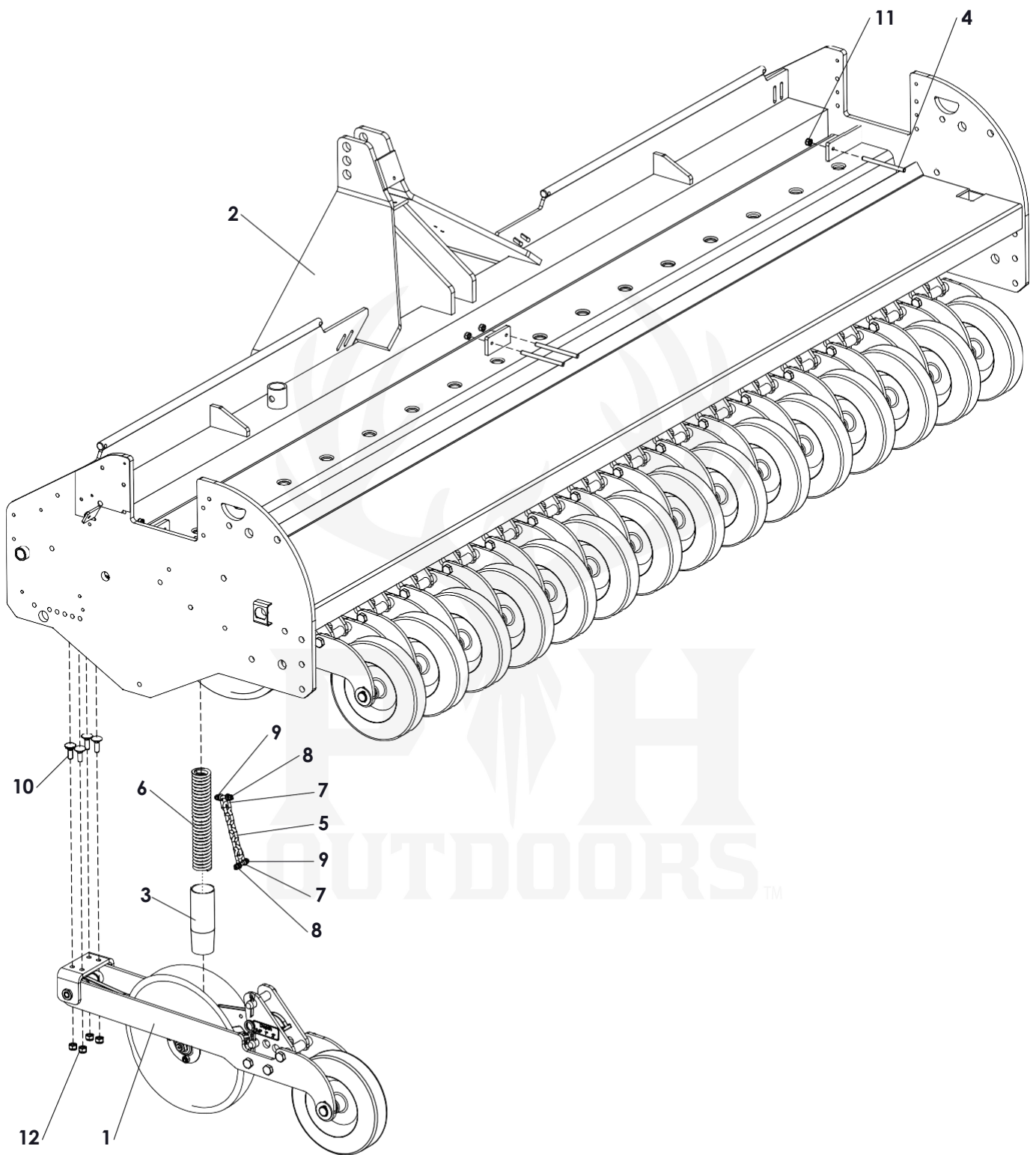

Pos.	Part number	Description	Qty.
1	See page 10	Seed element	16
2	G100016	Base frame G10	1
3	G000041	Seed guide	16
4	2310170	Threaded rod M10	4
5	3510806	Chain 6-links D=8mm L=152 (±6")	16
6	3705040	Compression spring disc assembly	16
7	3520800	D-Shackle d=8mm (complete with bolt and nut)	32
8	108045/10.9	Bolt M8 x 45 10.9	32
9	1708125	Self-Lock Nut M8	32
10	1312035	MH Bolt M12 x 35	64
11	1710150	Self-Lock Nut M10	4
12	1712175	Self-Lock Nut M12	64



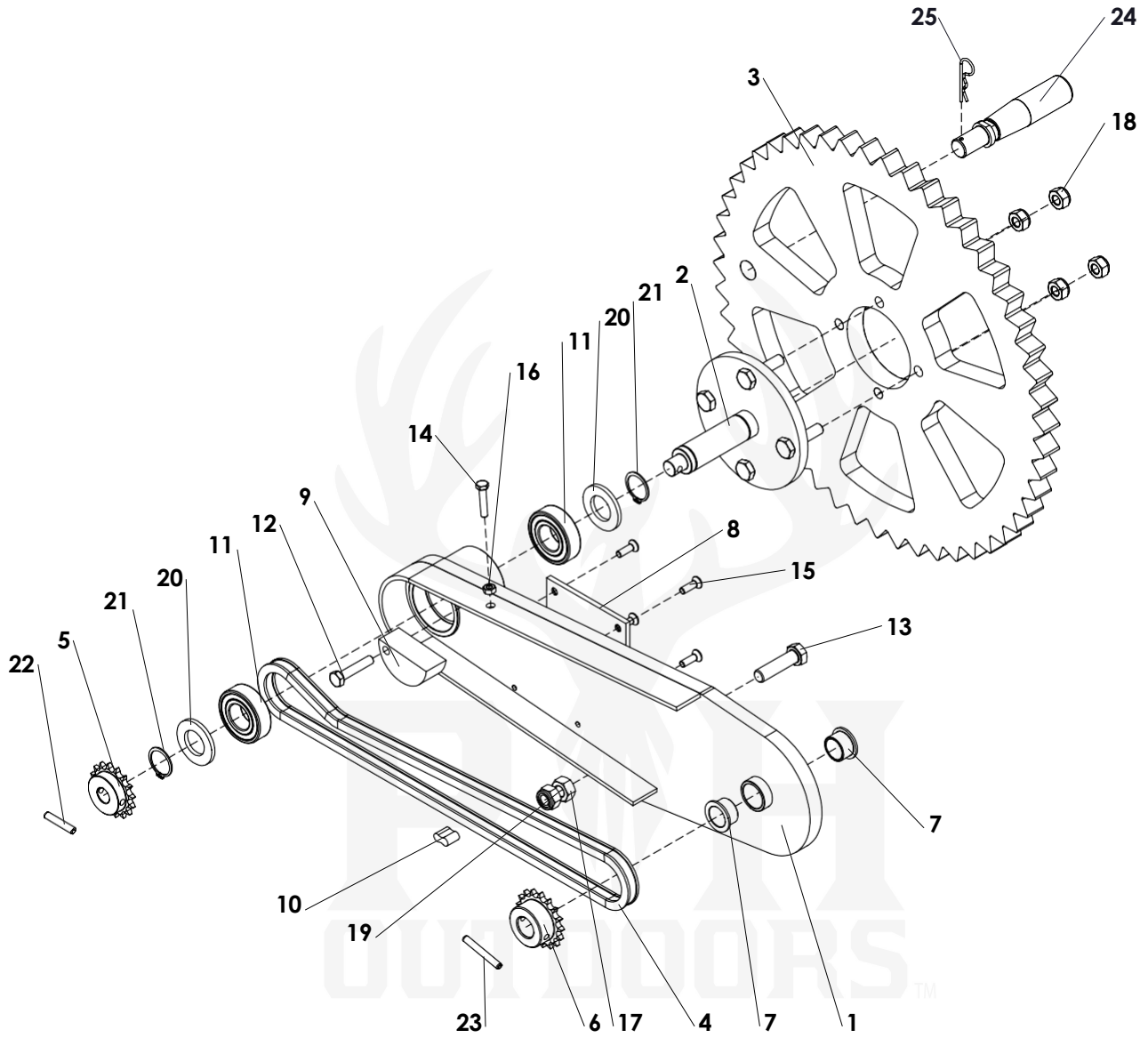

Pos.	Part number	Description	Qty.
1	G000035	Frame swingarm	1
2	G000036	Wheel hub	1
3	G000038	Drive wheel	1
4	3338106	Chain 3/8" Simplex L=978	1
5	G000039	Sprocket 3/8" (06B) simplex 16Z	1
6	G000040	Sprocket 3/8" (06B) simplex 17Z	1
7	3220152	Bearing bush swingarm	2
8	G000044	Guide plate swingarm	1
9	G000043	Chain tensioner	1
10	3438000	Chain connector 3_8 inch	1
11	2806205	Bearing 6205-LLU	2
12	1108040	Bolt M8 x 40	1
13	1112045	Bolt M12 x 45 Class 10.9	1
14	1006030	Bolt M6 x 30	1
15	1410620	Bolt M6 x 20	4
16	1806100	Nut M6	1
17	1812175	Nut M12	1
18	1710150	Self-Lock Nut M10	4
19	1712175	Self-Lock Nut M12	1
20	2212400	Washer M24	2
21	2612500	Circlip d=25	2
22	2406035	Roll Pin 6 x 35	1
23	2406045	Roll Pin 6 x 45	1
24	GDO-06	Handle	1
25	3830200	R-Clip D=2	1

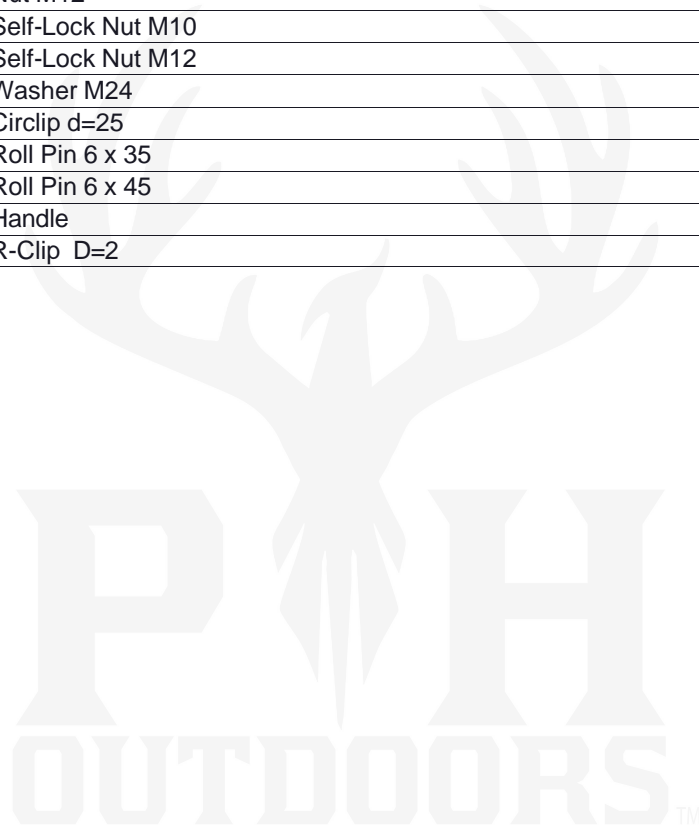

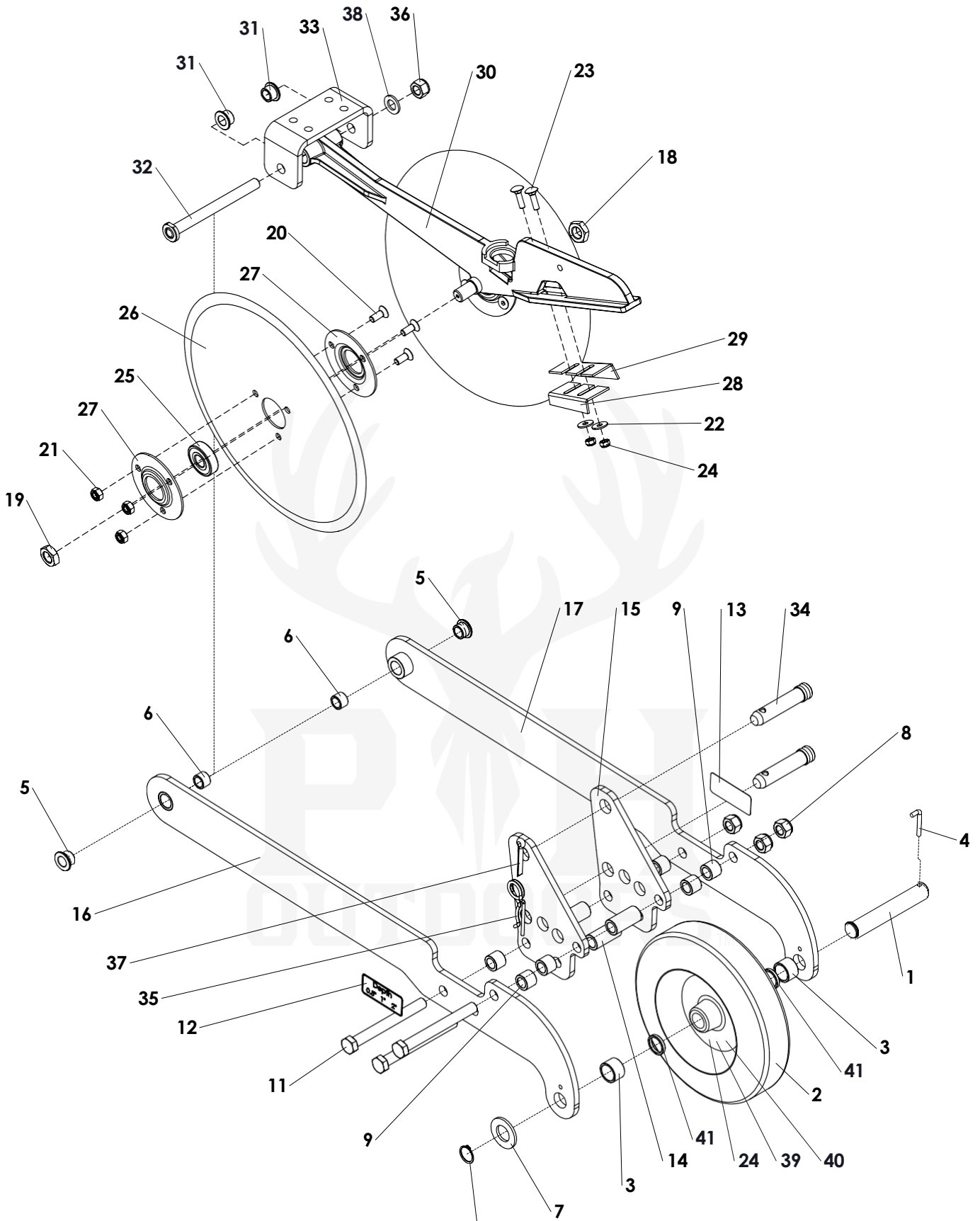

Seed elements per machine G3 : 5 elements

G5 : 8 elements

G8 : 13 elements

G10: 16 elements

!!! wheel replaced from serial nr G3 233079/G5 235222/G8 238032/G10 231005

Pos.	Part number	Description	Qty.
1	G000045	Shaft	1
2	4328071	Wheel complete will replace item nr 4328070	1
3	6025020	Distance bush	2
4	3830648	Lock pin	1
5	3216150	Bearing bush	2
6	3216155	Bearing bush	2
7	2212700	Washer 27 mm	1
8	1716200	Self-Lock Nut M16	3
9	6017020	Bush Ø16.5/Ø25 L=20	6
10	2612500	Circlip d=25	1
11	1116150	Bolt M16 x 150	3
12	4020003	Depth decal left	1
13	4020004	Depth decal right	1
14	6017052	Distance bush Ø25/Ø16.5 L=52	3
15	G000046	Height plate	2
16	G000047	Weldment seed element left	1
17	G000048	Weldment seed element right	1
18	1820002	Thin Nut M20 Right thread	1
19	1820002L	Thin Nut M20 Left thread !!!!	1
20	1411025	Bolt M10 x 25	6
21	1710150	Self-Lock Nut M10	6
22	2210801	Large washer M8	2
23	1308030	MH Bolt M8 x 30	2
24	1708125	Self-Lock Nut M8	8
25	2806304	Bearing 6304-LLU	2
26	G000049	Cutting disk Ø406	2
27	G000050	Center plate	2
28	G000051	Disc Scraper Large	1
29	G000052	Disc Scraper Small	1
30	G000053	Element	1
31	3216150	Bearing bush	2
32	G000054	Seeding element shaft	1
33	G000055	U holding bracket	1
34	3822112	Pin for 3-point	2
35	3830500	R-clip Round 5	1
36	1716200	Self-Lock Nut M16	1
37	2408050K	Cotter Pin 8 x 50	1
38	2211600	Washer M16	1
39	1008016	Bolt M8 x 16	6
40	2806205	Bearing 6205-LLU	2
41	6025005	Distance washer	2

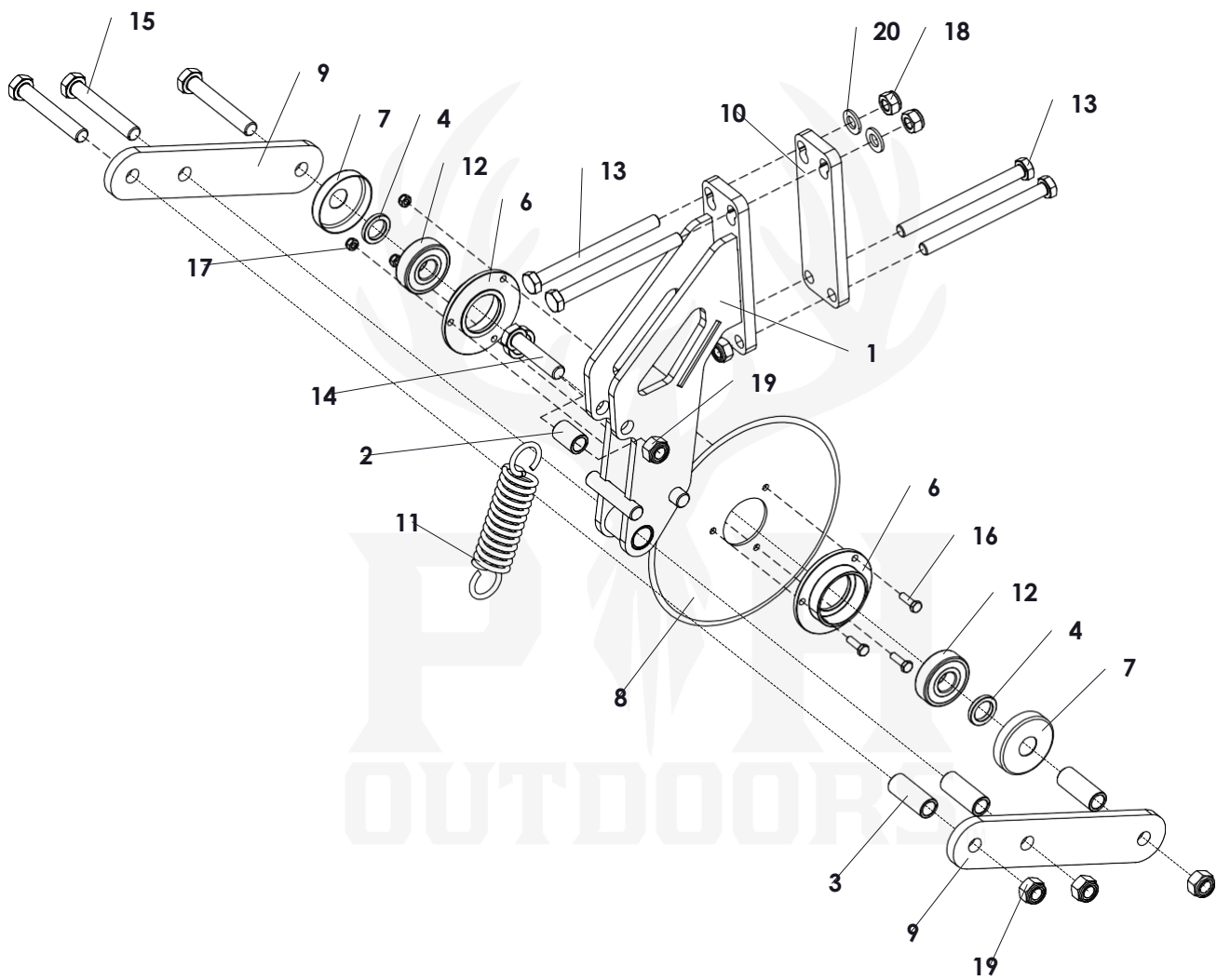

Coulters kits per machine

- G3 : 5 kits
- G5 : 8 kits
- G8 : 13 kits
- G10: 16 kits

Pos.	Part number	Description	Qty.
1	G000056	Support bracket	1
2	6014290	Distance bush Ø20/Ø14.2 L=29	1
3	6014500	Distance bush Ø20/Ø14.2 L=50	3
4	6021045	Distance bush	2
5	6021009	Distance bush Ø30/Ø20.5 L=9	1
6	G000057	Bearing block	2
7	G000058	Dust cover	2
8	G000059	Disc Ø220/ 3mm	1
9	G000060	Arm	2
10	G000061	Lock plate	1
11	3640127	Spring	1
12	2806304	Bearing 6304-LLU	2
13	1112140	Bolt M12 x 140	4
14	111406510.9	Bolt M14 x 65 10.9	1
15	1114090	Bolt M14 x 90	3
16	1006020	Bolt M6 x 20	3
17	1706100	Self-Lock Nut M6	3
18	1712175	Self-Lock Nut M12	4
19	1714200	Self-Lock Nut M14	4
20	2211200	Washer M12	2
	GDO-04	Coulter knife kit include pos. 1 till 20	

G3 need 5 coulter kits for the complete machine
G5 need 8 coulter kits for the complete machine
G8 need 13 coulter kits for the complete machine
G10 need 16 coulter kits for the complete machine

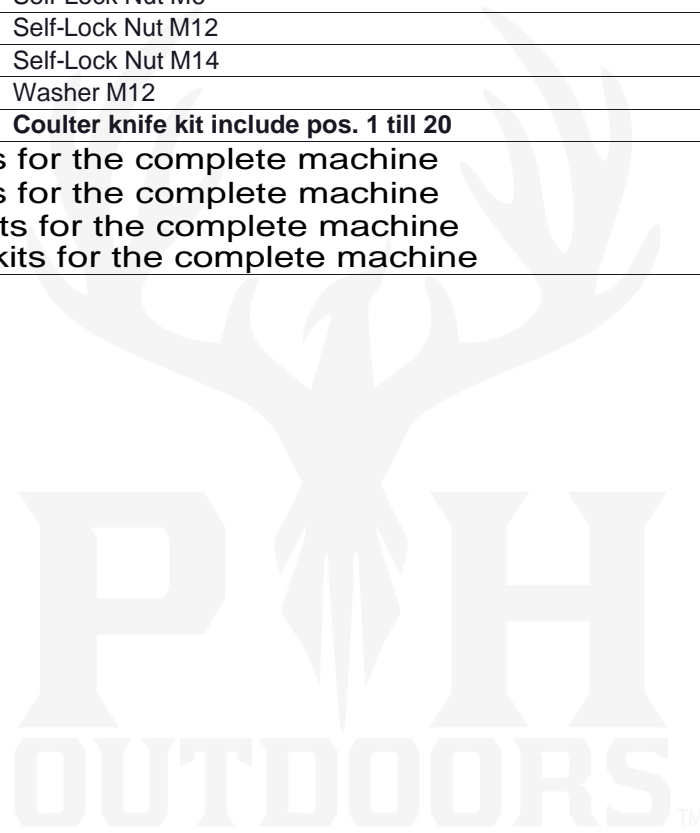

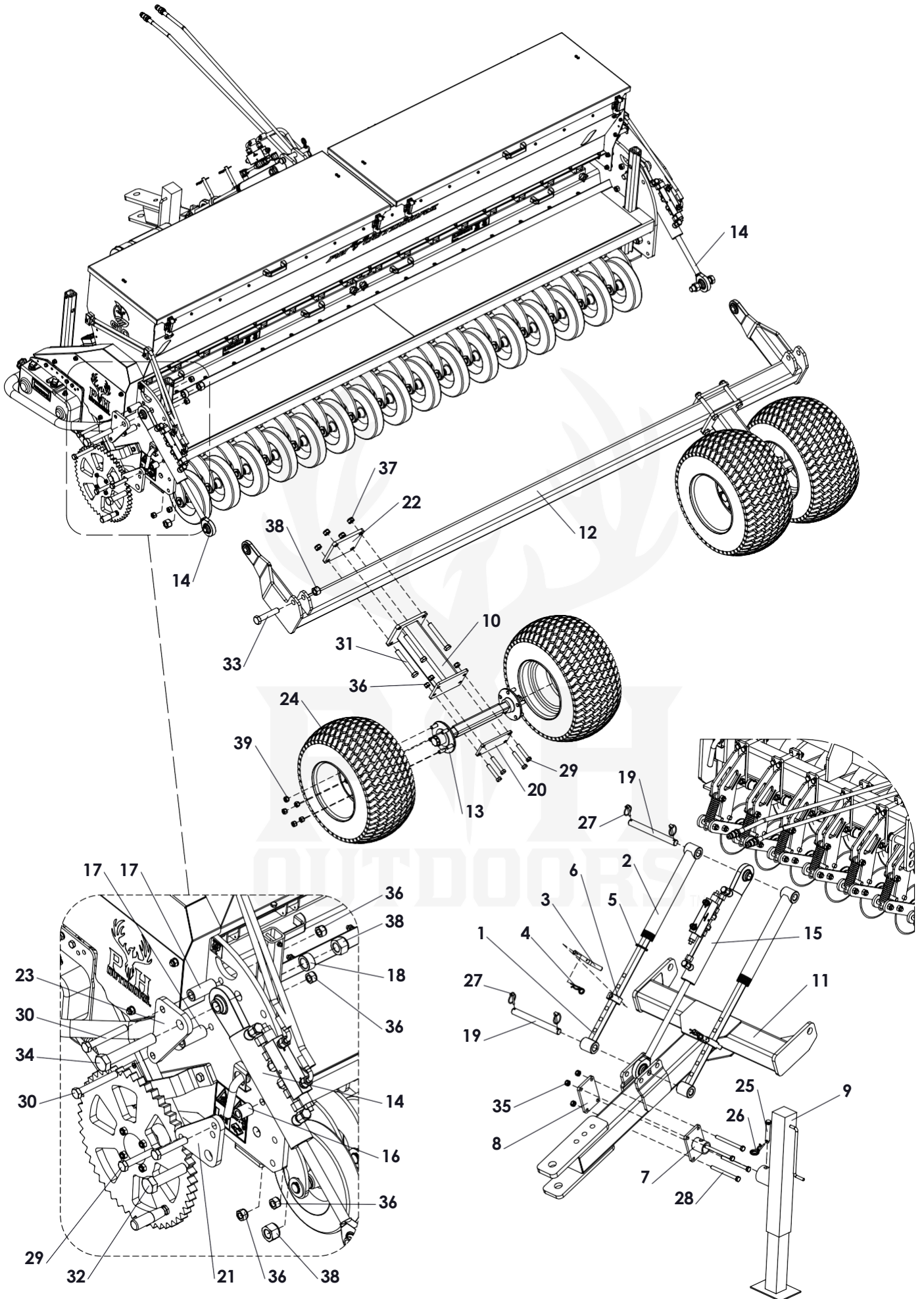

Pos.	Part number	Description	Qty.
1	G100017	Hex stop inner	2
2	G100018	Hex stop outer	2
3	G100019	Lock pin	2
4	3830300	R-Clip Round 3, DIN 11024	2
5	G100020	Distance bush $\varnothing 51/\varnothing 38.4$ L=5	12
6	G100021	Bush	2
7	G100022	Mounting hub	1
8	G100023	Mounting Plate	1
9	G100024	Spindle	1
10	G100025	Axle spacer	2
11	G100026	Drawbar G10	1
12	G100027	Bogy frame G10	1
13	G100028	Wheel axle 5xM16 50x50 L=450	2
14	G100029	Cylinder assembly (Pag 14b)	2
15	G100030	Cylinder assembly (Pag 14a)	1
16	G100031	Distance bush $\varnothing 30/\varnothing 16.5$ L=38	4
17	G100032	Distance bush $\varnothing 30/\varnothing 16.5$ L=71	4
18	G100033	Distance bush $\varnothing 40/\varnothing 26$ L=20	2
19	G100034	Link pin	2
20	G100035	Clamp strip	2
21	G100036	Mounting plate	2
22	G100037	Mounting plate	2
23	G100038	Cylinder contra plate	2
24	4326120	Wheel 26x12 inch complete	4
25	3821610	Top link pin Cat. 0 - 16.1 x 100	1
26	3830500	R-clip Round	1
27	3830601	Linch pin $\varnothing 6$	4
28	1112140	Bolt M12 x 140	4
29	1116090	Bolt M16 x 90	12
30	1116120	Bolt M16 x 120	4
31	1120150	Bolt M20 x 150	8
32	1610100	Hex Bolt 1"-8x4.0" UNC	2
33	1610125	Hex Bolt 1"-8x5" UNC	2
34	1610150	Hex Bolt 1"-8x6" UNC	2
35	1712175	Self-Lock Nut M12	4
36	1716200	Self-Lock Nut M16	20
37	1720250	Self-Lock Nut M20	8
38	1910001	Self-Lock Nut 1 inch UNC	6
39	2016001	Wheel Nut M16	20

OUTDOORS™

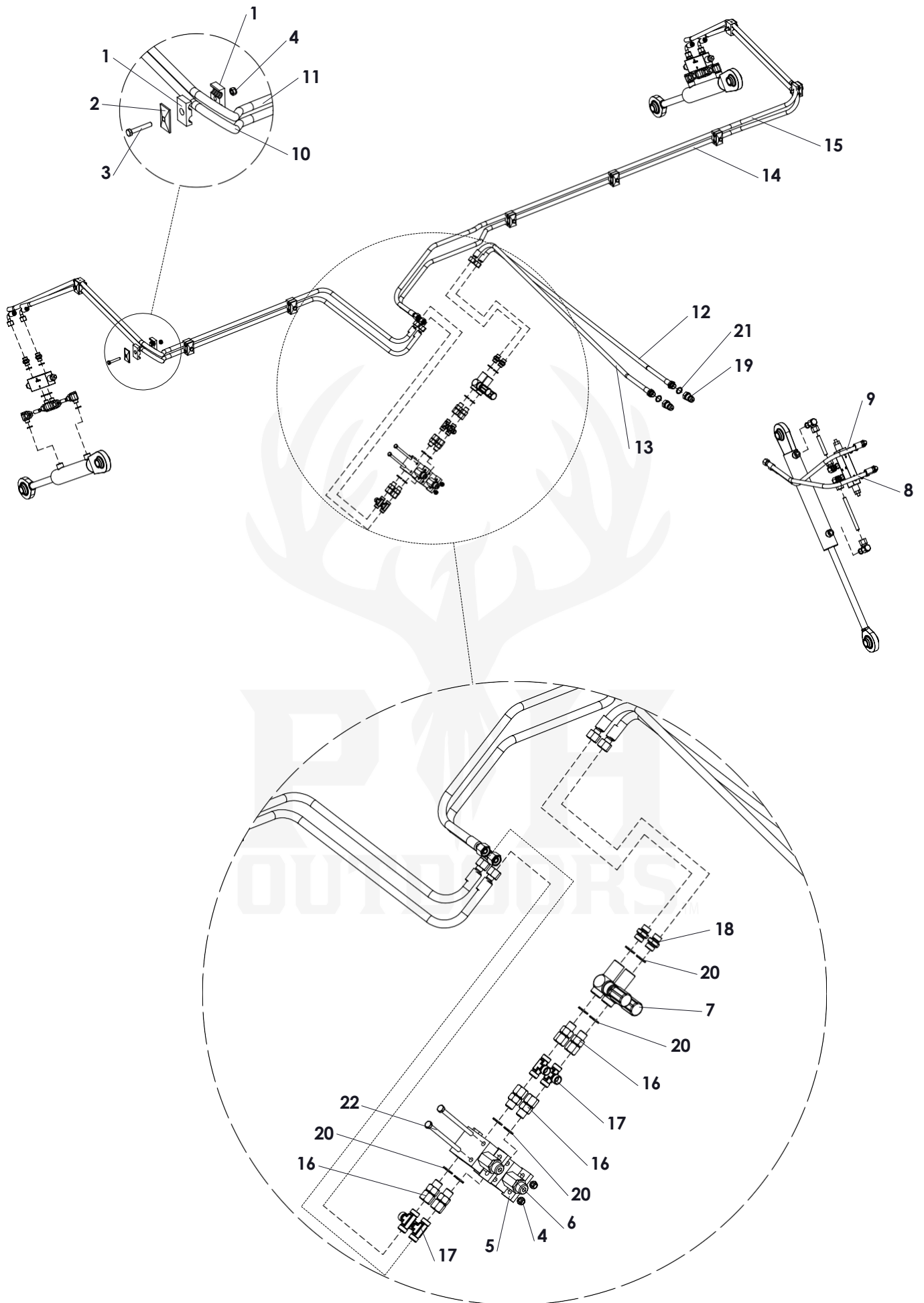

Pos.	Part number	Description	Qty.
1	8015150	Hose clamp double 15mm	18
2	8015151	Cover plate hose clamp 2x15 - 2x18	9
3	1108050	Bolt M8 x 50 - ISO 4014	9
4	1708125	Self-Lock Nut M8 - ISO 10511	11
5	G100039	Strip	2
6	8800006	Sequence valve VDSDB05001	2
7	8800002	Flow reducer 3/8" FPU05001	2
8	G100040	Hose NSK10-3/8" TL=830 PGLO101890+PGLO1018	1
9	G100040	Hose NSK10-3/8" TL=830 PGLO101890+PGLO1018	1
10	G100041	Hose NSK10-3/8" TL=2450 PGLO101890+PGLO1018	1
11	G100042	Hose NSK10-3/8" TL=2600 PGLO101890+PGLO1018	1
12	G100043	Hose NSK10-3/8" TL=2500 PGLO1018+PN108	1
13	G100043	Hose NSK10-3/8" TL=2500 PGLO1018+PN108	1
14	G100044	Hose NSK10-3/8" TL=3350 PGLO101890+PGLO1018	1
15	G100045	Hose NSK10-3/8" TL=3500 PGLO101890+PGLO1018	1
16	8638120	Joint Connector Straight 3/8" x Ø12 Prem.	6
17	8112121	T-Connector 12x12x12	4
18	8238120	Nipple BSP 3_8" x pipe 12 (M18)	2
19	8800001	Quick connector male 1/2"	2
20	2233800	Copper washer 3_8	8
21	2231200	Copper washer 1_2	2
22	1108110	Bolt M8 x 110 - ISO 4014	2

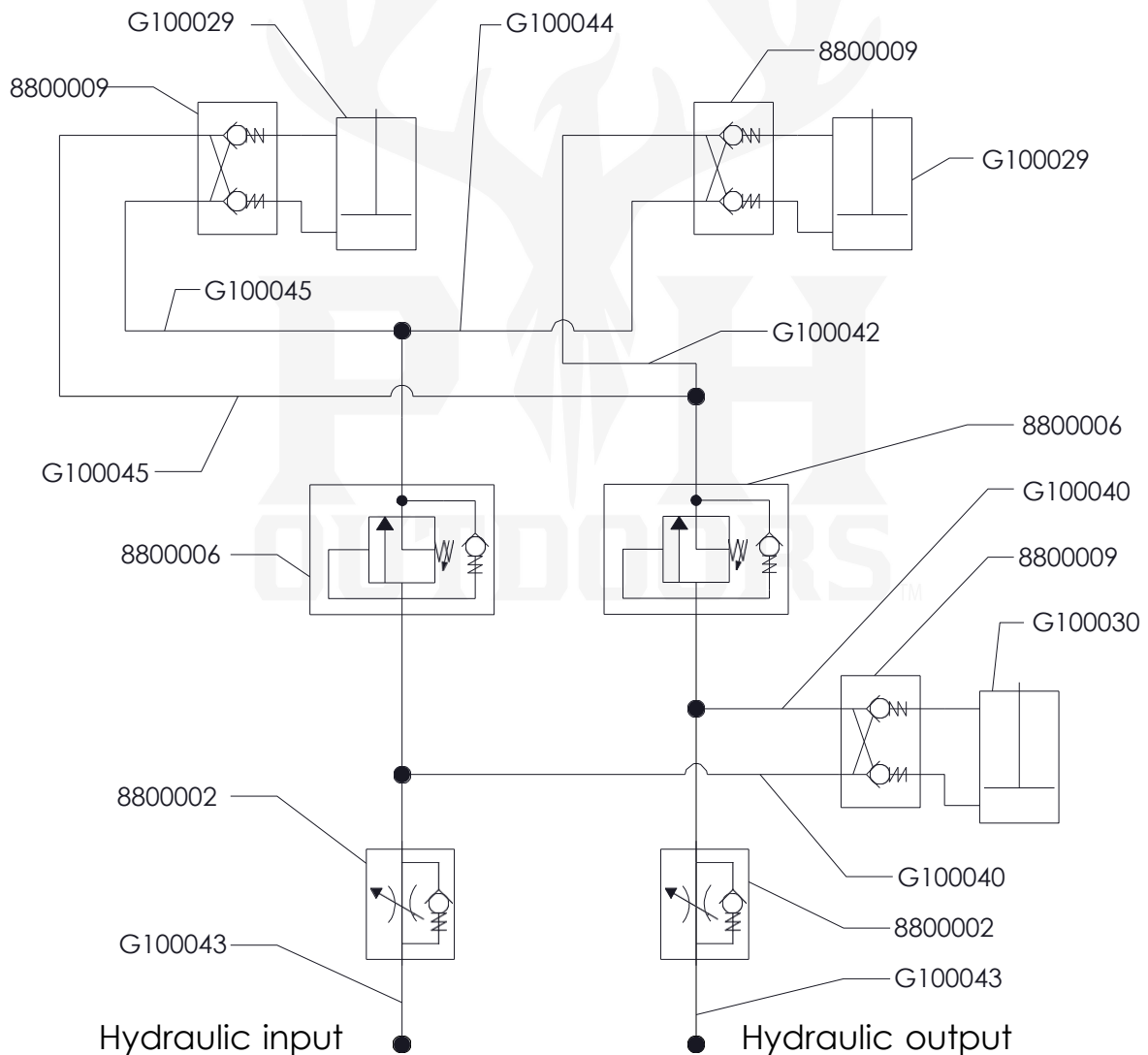

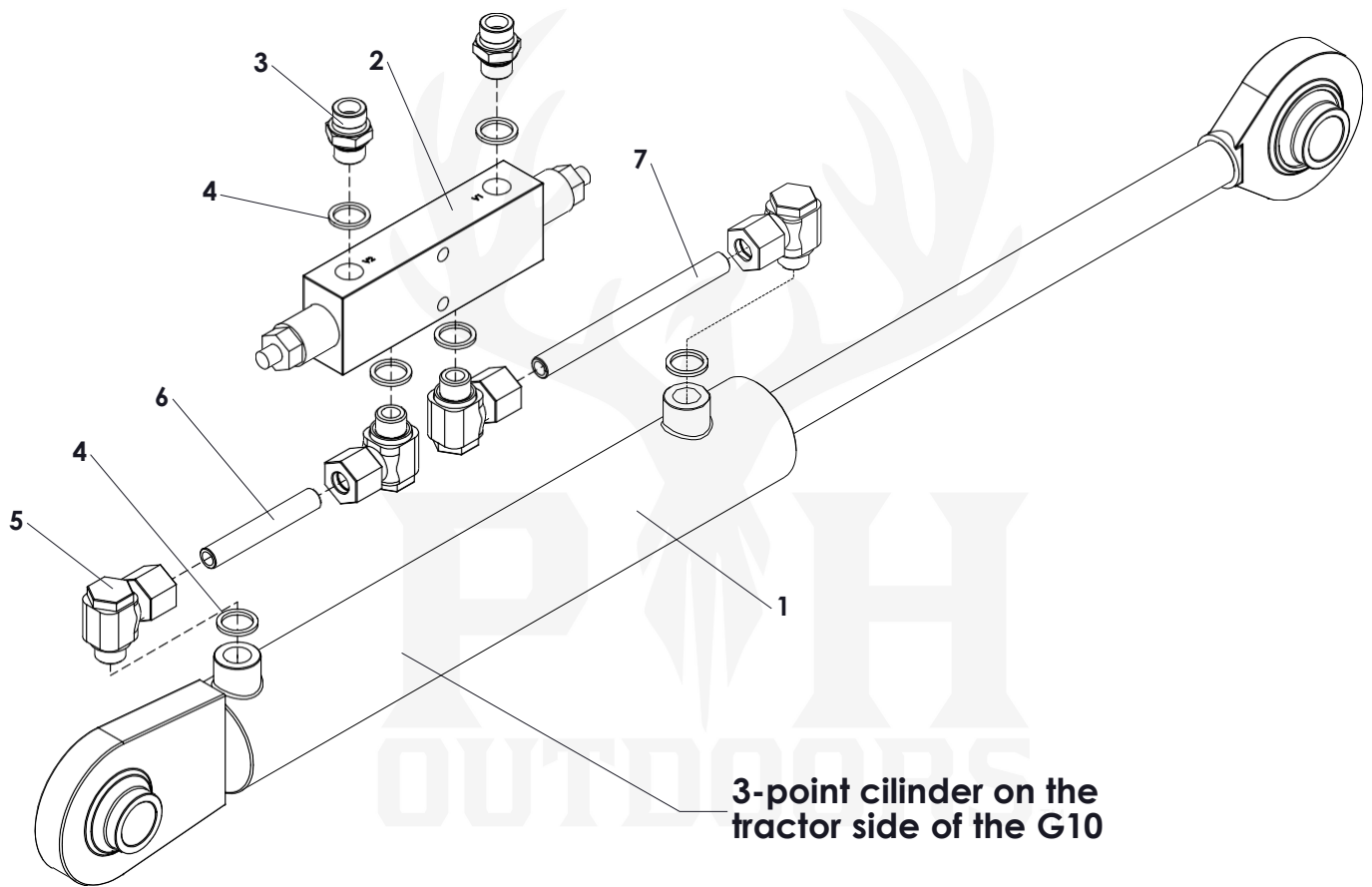

Pos.	Part number	Description	Qty.
1	8800007	Hydraulic cylinder 25-50, Stroke=300	1
2	8800009	Double equalising valve 3/8"	1
3	8238120	Nipple BSP 3_8" x pipe 12 (M18)	2
4	2233800	Copper washer 3_8	6
5	8438120	L-connector G3/8-12mm	4
6	G100046	Tube 12x80	1
7	G100047	Tube 12x135	1
	G100030	Hydraulic cylinder complete include pos. 1 till 7	



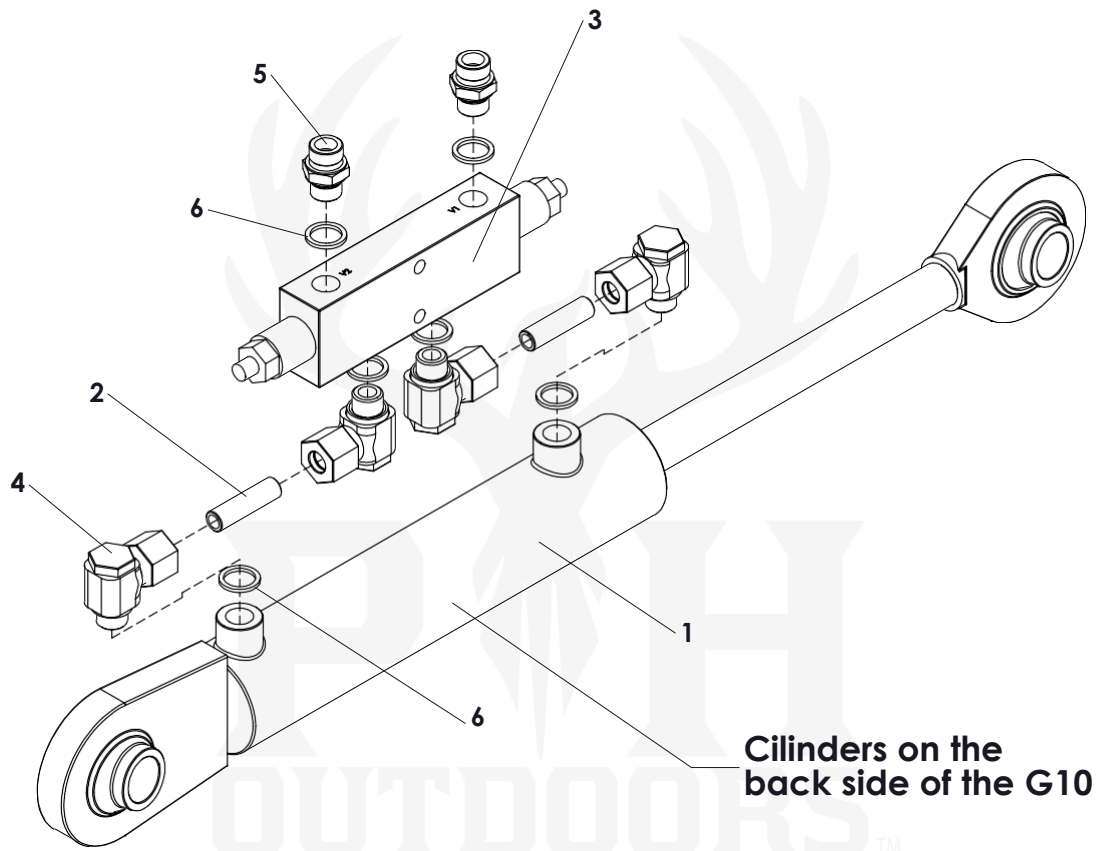

Pos.	Part number	Description	Qty.
1	8800008	Hydraulic cylinder 25-50 Stroke=200	1
2	G100048	Tube 12 x 45	2
3	8800009	Double equalising valve 3/8"	1
4	8438120	L-connector G3/8-12mm	4
5	8238120	Nipple BSP 3_8" x pipe 12 (M18)	2
6	2233800	Copper washer 3_8	6
	G100029	Hydraulic cylinder complete include pos. 1 till 6	



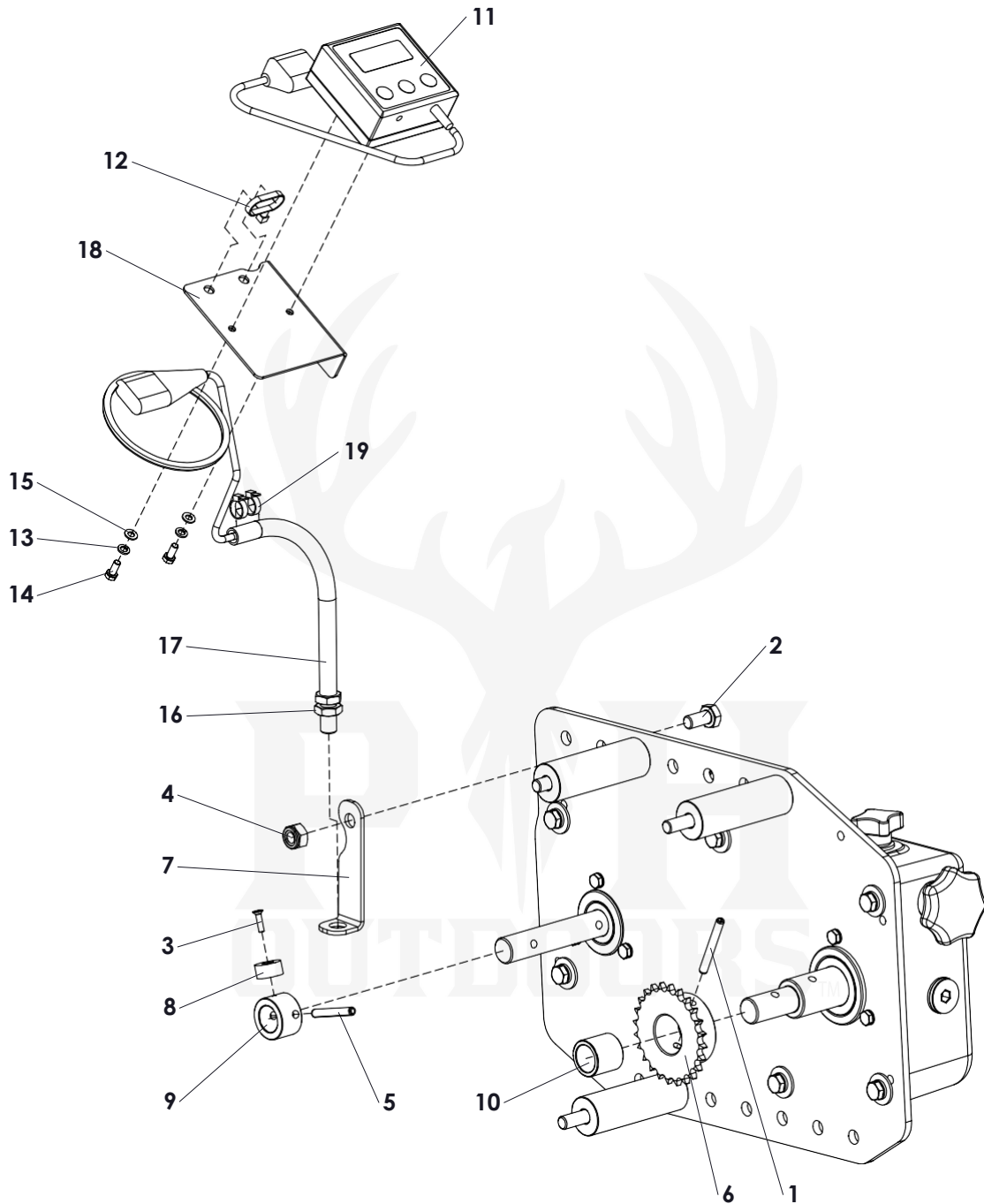

Pos.	Part number	Description	Qty.
1	2406050	Roll Pin 6 x 50	1
2	1010020	Bolt M10 x 20	1
3	1410416	Bolt M4 x 16	1
4	1710150	Self-Lock Nut M10	1
5	2406045	Roll Pin 6 x 45	1
6	G000083	Sprocket 3/8" Z24	1
7	G000033	Sensor bracket	1
8	G000084	Magnet	1
9	G000085	Magnet bush	1
10	G000086	Bush	1
11	G000087	Counter UC300	1
12	3900007	Cable-tie 4.8x200	1
13	2220500	Spring Washer M5	2
14	1005012	Bolt M5 x 12	2
15	2210500	Washer M5	2
16	G000088	Magnetic sensor D10 + cable + magnet	1
17	3900006	Protection tube open, L=210mm	1
18	G000089	Bracket counter	1
19	3900007	Cable-tie 4.8x200	2



Gearbox assembly

DETAIL A
SCALE 1 : 3

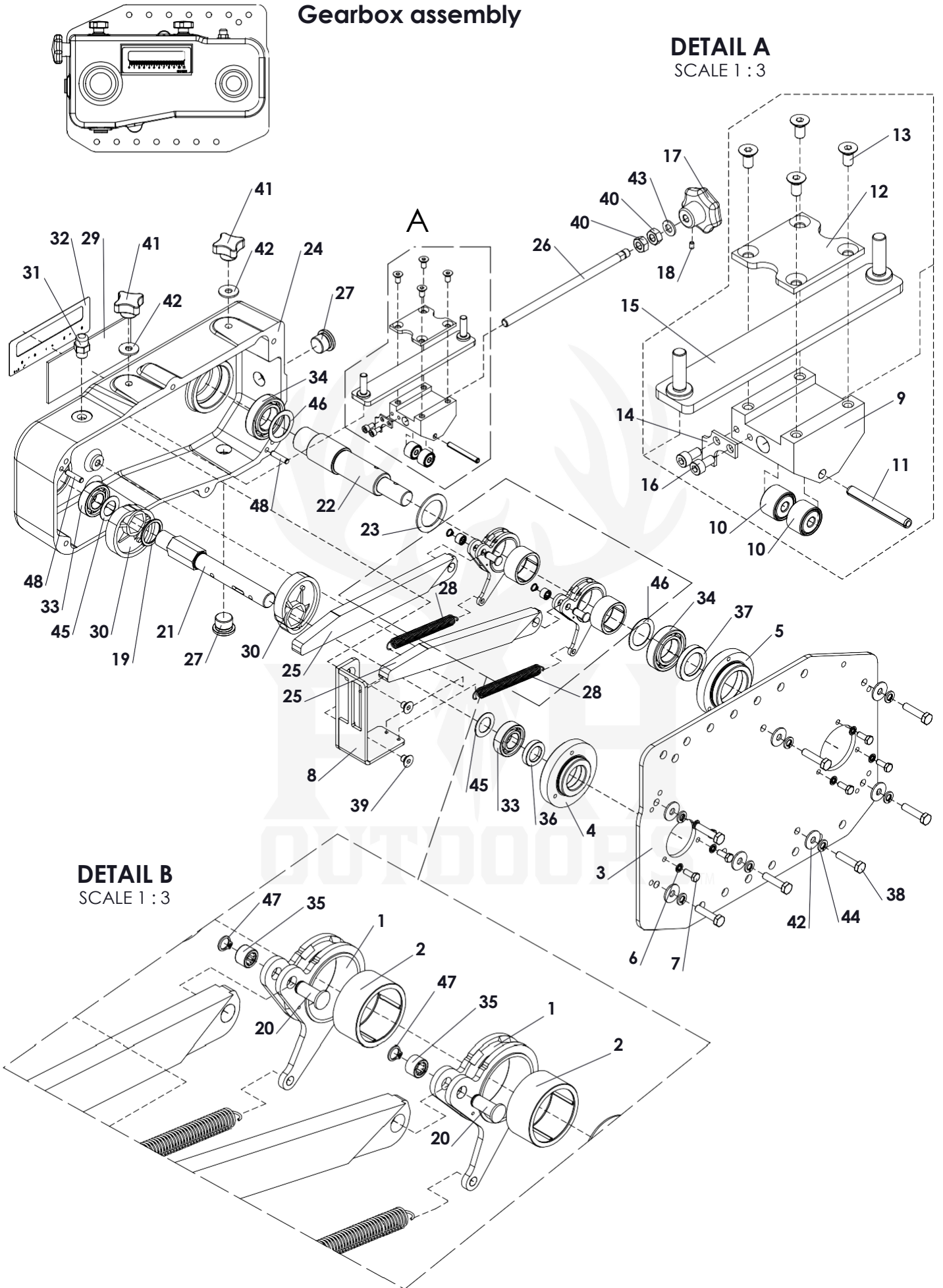

DETAIL B
SCALE 1 : 3

Pos.	Part number	Description	Qty.
1	G000025	Rocker arm	2
2	2703520	Bearing HF3520	2
	G000093	Rocker arm assy include pos.1+2	2
3	G000062	Lid plate	1
4	G000091	Bearing hub Ø42	1
5	G000092	Bearing hub Ø55	1
6	2250600	Bonded seal ring M6	6
7	1006016	Bolt M6 x 16	6
8	G000063	Guide	1
9	G000064	Slider block	1
10	2700612	Roller bearing	2
11	2406050	Roll Pin 6 x 50	1
12	G000067	Lock plate	1
13	1410612	Bolt M6 x 12	4
14	G000068	Indicator	1
15	G000069	Slider bracket	1
16	1420510	Inner hexagon bolt M5 x 10	2
17	G000070	Knurled knob M10x63	1
18	2505008	Set screw M5 x 8	1
19	G000071	Spacer	1
20	G000072	Pin	2
21	G000073	Shaft	1
22	G000074	Shaft	1
23	G000075	Washer	1
24	G000076	Casted gearbox housing	1
25	G000077	Rocker strip	2
26	G000078	Threaded rod M10x210	1
27	8712001	Blind plug G1/2	2
28	G000079	Spring	2
29	G000080	Window	1
30	G000081	Excenter	2
31	8714002	Breather 1/4"	1
32	G000082	Gauge decall	1
33	2706004	Bearing 6004	2
34	2706006	Bearing 6006	2
35	2700808	Bearing HK0808	2
36	7020320	Oil seal 20-32-7	1
37	7030450	Oil seal 30-45-8	1
38	1008035	Bolt M8 x 35	7
39	1410810	Bolt M8 x 10	2
40	1810150	Nut M10	2
41	1808002	Closed Knob M8	2
42	2210801	Large washer M8	9
43	2211000	Washer M10	1
44	2220800	Spring Washer M8	7
45	2242010	Shim Ø20xØ32x1.0	2
46	2243010	Shim Ø30xØ42x1.0	2
47	2610800	Circlip d=8	2
48	2406026/P	Parallel pin 6 x 26	2
	G000090	Speed adjustable box complete (include pos. 1 till 48)	

Without side cover

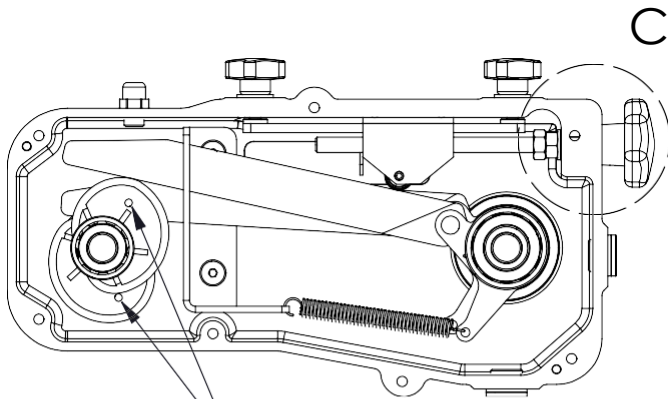

DETAIL C

SCALE 1 : 2

Mount knob as far as possible on threaded rod and adjust set screw

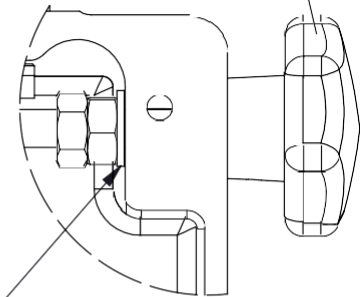

Keep $\pm 2\text{mm}$ clearance distance between washer and casting! Adjustment must rotate smooth.

Warning!

Make sure the excenters are positioned correct:

- The nodge has to be faced outwards.
 - Timing: 180° shifted from each other
- If not correctly installed a shocked rotation will occur at the output shaft.

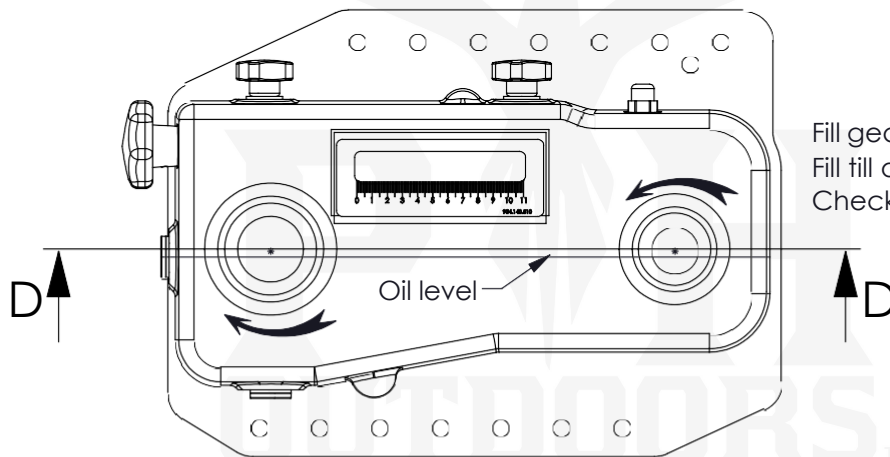

Fill gearbox with $\pm 1,4\text{L}$ 80W90 oil
Fill till oil level line
Check for leakage after filling

SECTION D-D

SCALE 1 : 5

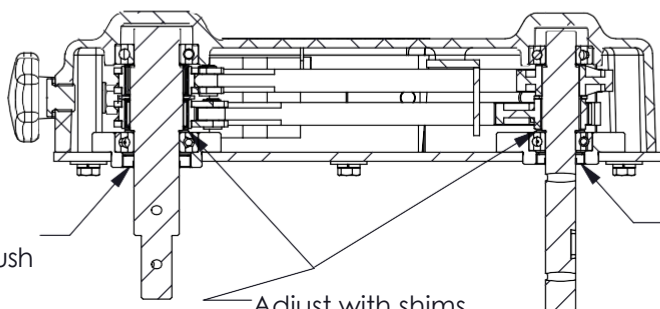

Outside seal even to outside bush

Outside seal even to outside bush

Adjust with shims.
Free play: $\pm 0 - 0.5\text{mm}$