

PH OUTDOORS™

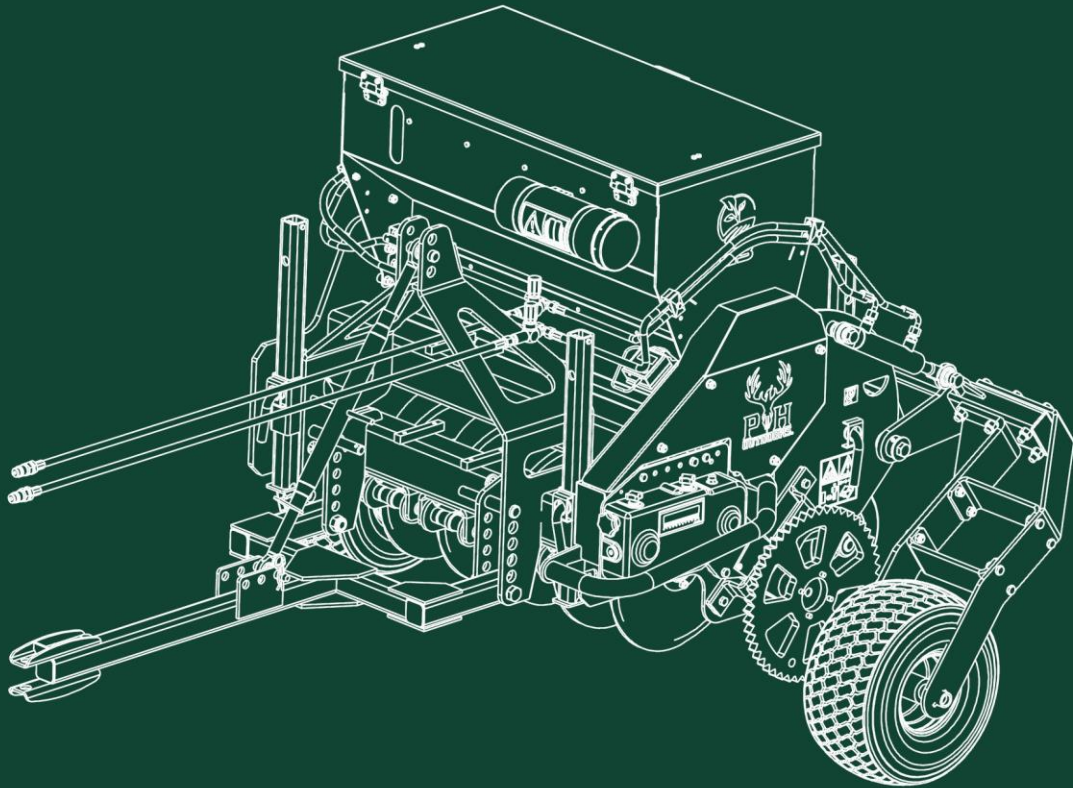

G3 No-Till Drill Original Parts Manual



*Illustrations may include optional items that are not included in standard package

PH Outdoors, LLC

P.O. Box 480
Eureka, MO 63025

Parts Book
Revision 040924

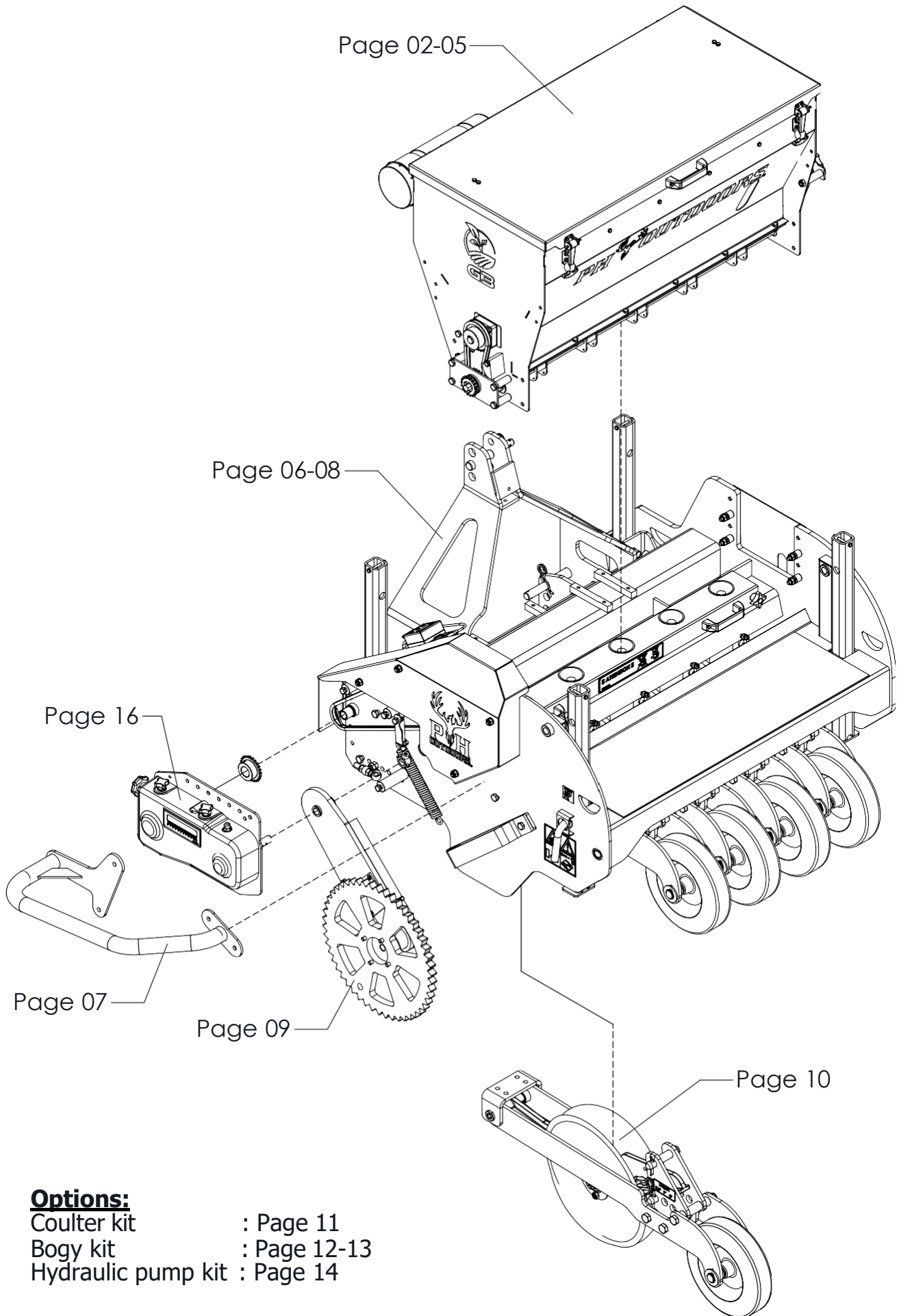

Options:

- Coultter kit : Page 11
- Bogy kit : Page 12-13
- Hydraulic pump kit : Page 14

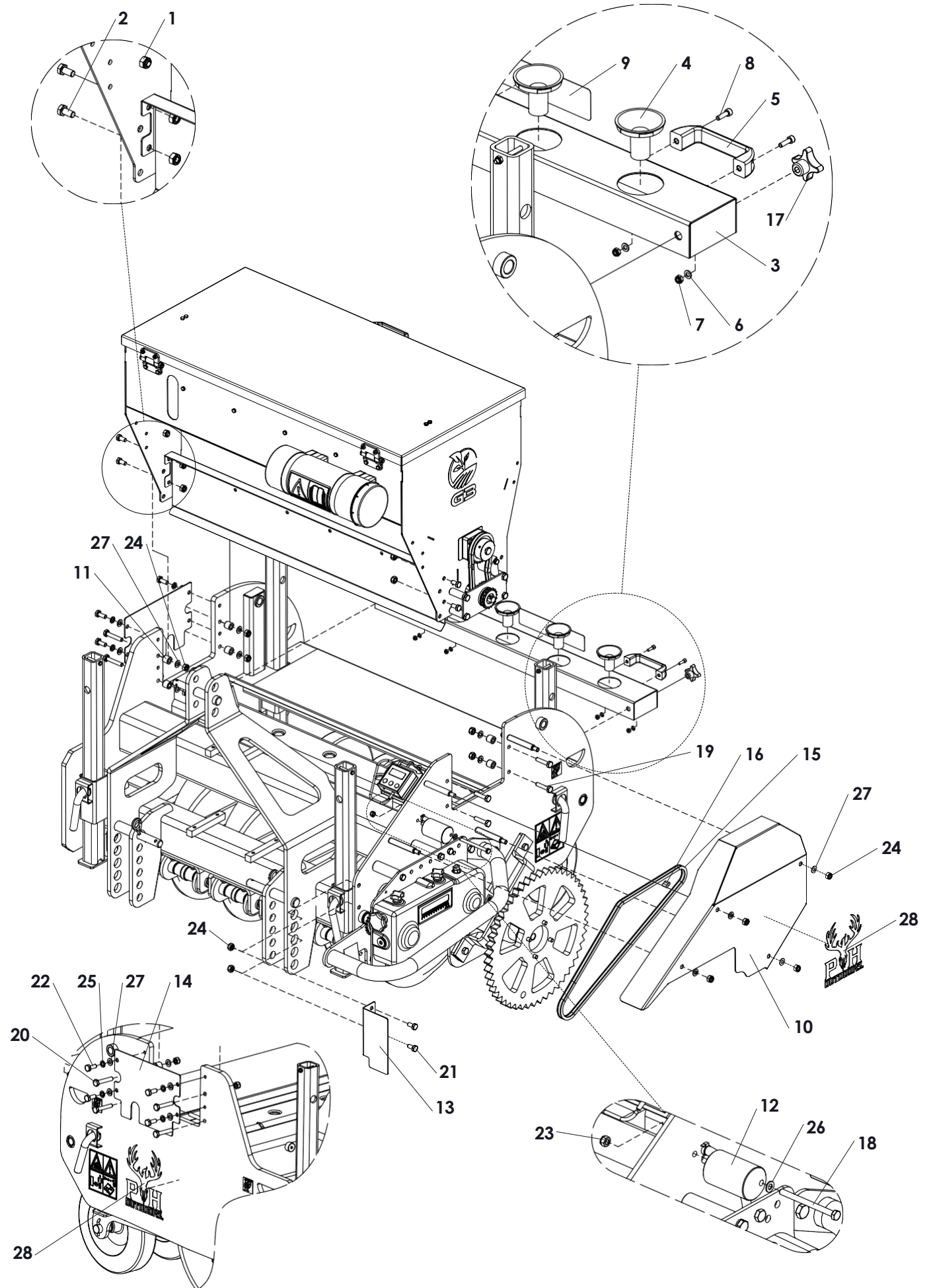

Pos.	Part number	Description	Qty.
1	1710150	Self-Lock Nut M10	18
2	1010020	Bolt M10 x 20	4
3	G300001	Funnel frame	1
4	G000029	Funnel	5
5	3900002	Handle	2
6	2210600	Washer M6	4
7	1706100	Self-Lock Nut M6	4
8	1420620	Bolt M6 x 20	4
9	4010001	Decal funnel	1
10	G000001	Cover G machine	1
11	6010182	Distance bush	8
12	G300032	Spanner	1
13	G000034	Cover plate	1
14	G000002	Cover plate	1
15	3338131	Chain 3/8" 131 shackle	1
16	3438000	Chain connector 3/8"	1
17	1810001	Knob M10	2
18	1108100	Bolt M8 x 100	1
19	1110045	Bolt M10 x 45	4
20	1110055	Bolt M10 x 55	4
21	1010020	Bolt M10 x 20	2
22	1010025	Bolt M10 x 25	4
23	1708125	Self-Lock Nut M8	1
24	1710150	Self-Lock Nut M10	16
25	2221000	Spring Washer M10	4
26	2210600	Washer M6	1
27	2211000	Washer M10	18

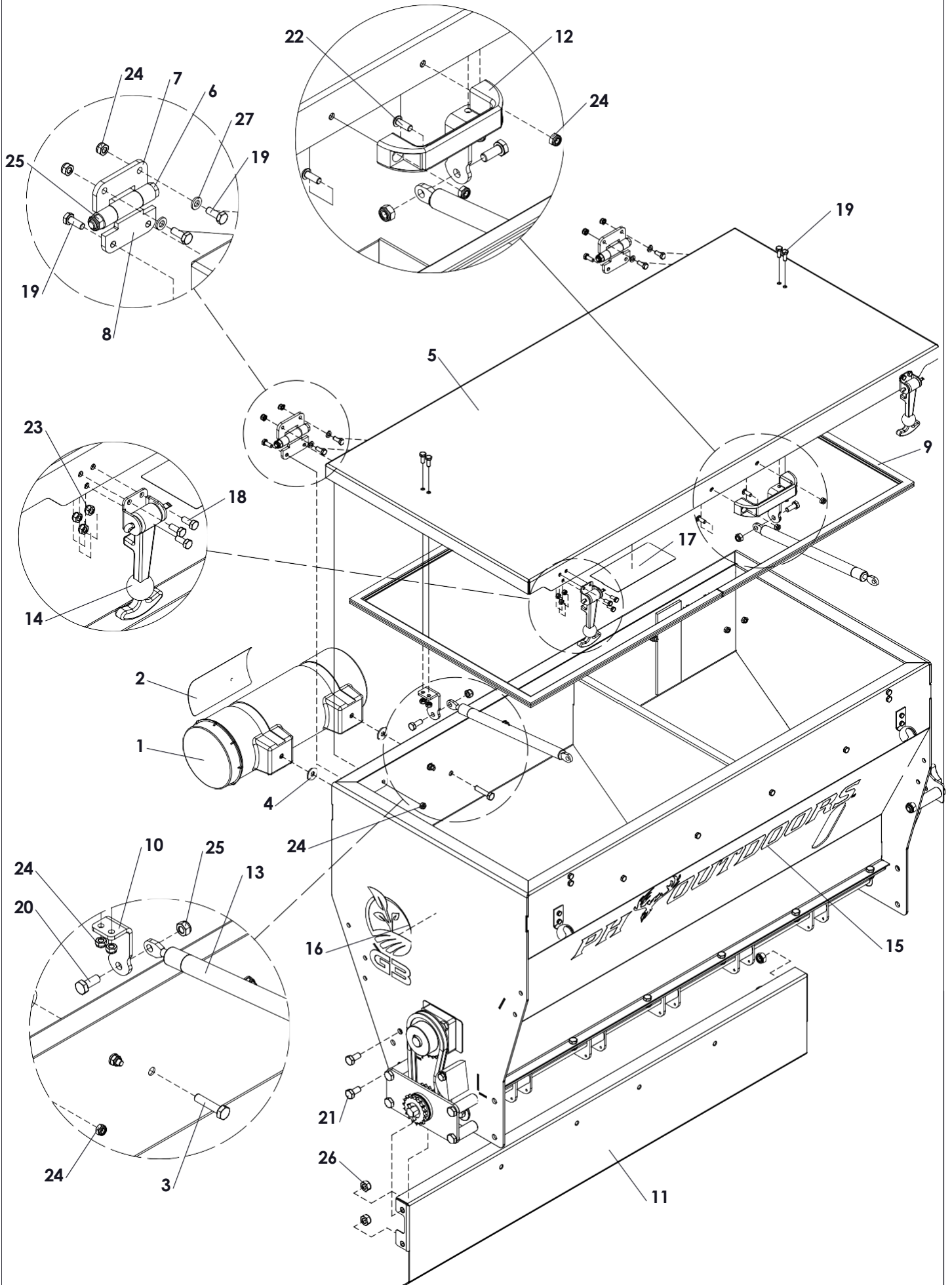

Pos.	Part number	Description	Qty.
1	3900003	Toolbox assembly	1
2	4010002	Safety decal manual	1
3	1008035	Bolt M8 x 35	2
4	2210801	Large washer M8	2
5	G300002	Top cover	1
6	1108075	Bolt M8 x 75	2
7	G000003	Hinge part 1	1
8	G000004	Hinge part 2	1
9	G300003	Rubber U-seal	1
10	G000005	Support L=65mm	2
11	G300004	Cover plate	1
12	3900002	Handle	1
13	G000028	Gas strut	2
14	3900005	Rubber lock assy	2
15	4020000	Label PH Outdoors	1
16	G300005	Label G3	2
17	4200009	Label warning seed hopper	1
18	1005012	Bolt M5 x 12	10
19	1006016	Bolt M6 x 16	52
20	1008020	Bolt M8 x 20	4
21	1010020	Bolt M10 x 20	4
22	2106016	Bolt M6 x 16	2
23	1705080	Self-Lock Nut M5	10
24	1706100	Self-Lock Nut M6	54
25	1708125	Self-Lock Nut M8	19
26	1710150	Self-Lock Nut M10	18
27	2210600	Washer M6	20

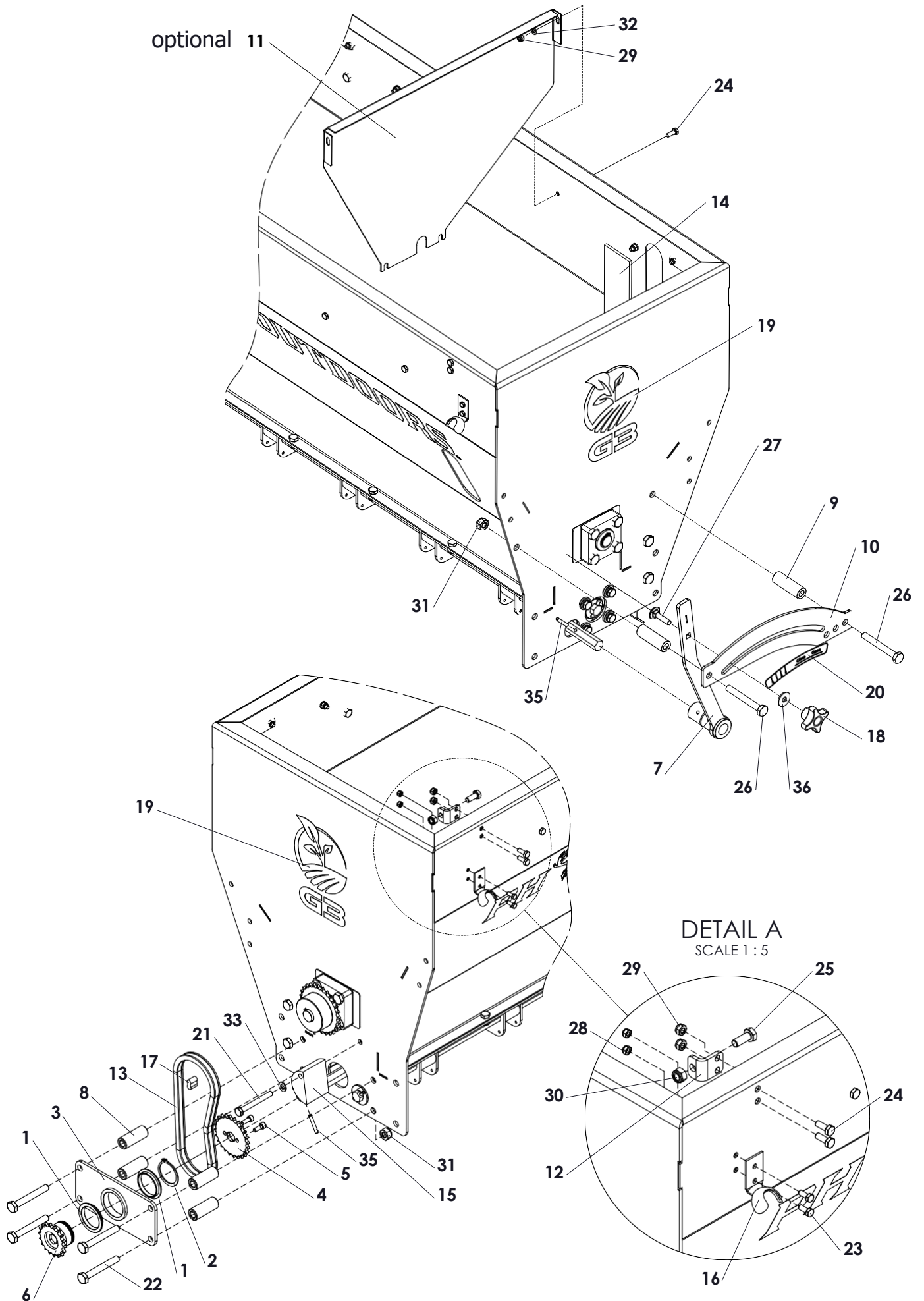

Pos.	Part number	Description	Qty.
1	3240070	Bearing bush	2
2	2614000	Circlip d=40	1
3	G000006	Gear base	1
4	G000007	Sprocket 3/8"	1
5	1420616	Bolt M6 x 16	2
6	G000008	Sprocket 3/8"	1
7	G000009	Handle	1
8	6010050	Distance bush	4
9	6010060	Distance bush	2
10	G000011	Guide strip	1
11	GDO-02	Divider plate (optional)	4
12	G000026	Support	2
13	3338063	Chain 3/8" 63 shackle	1
14	G000027	Window	2
15	G000012	Chain Tensioner	1
16	3900005	Bracket for latch	2
17	3438000	Chain connector 3_8	1
18	1808001	Knob M8	1
19	G300005	Label G3	2
20	4020005	Label adjustment valve	1
21	1108070	Bolt M8 x 70	1
22	1110075	Bolt M10 x 75	4
23	1005012	Bolt M5 x 12	5
24	1006016	Bolt M6 x 16	52
25	1008020	Bolt M8 x 20	4
26	1110080	Bolt M10 x 80	2
27	1308035	MH Bolt M8 x 35	1
28	1705080	Self-Lock Nut M5	5
29	1706100	Self-Lock Nut M6	54
30	1708125	Self-Lock Nut M8	17
31	1710150	Self-Lock Nut M10	18
32	2210600	Washer M6	20
33	2210800	Washer M8	1
34	2211001	Large washer M10	9
35	2405032	Roll pin Ø5x32	4
36	2210801	Large washer M8	1

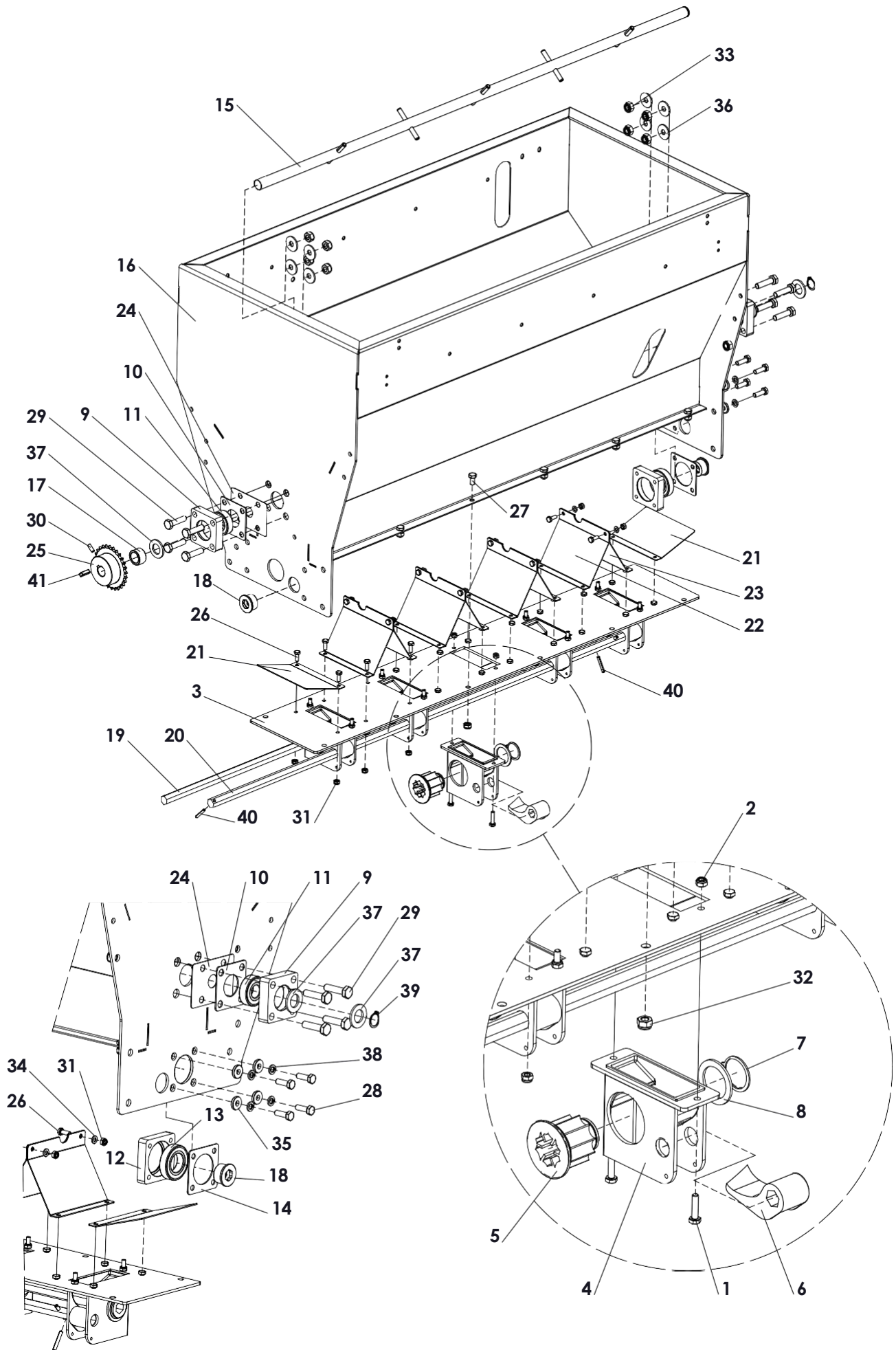

Pos.	Part number	Description	Qty.
1	1006025	Bolt M6 x 25	10
2	1706100	Self-Lock Nut M6	10
3	G300033	Plate	1
4	G000013	Seed element casing	1
5	G000014	Seed element rotor	1
6	G000015	Seed element valve	1
7	2613200	Circlip d=32	1
8	G000016	Washer	1
9	G000017	Bearing block	2
10	G000018	Cover plate large hole	2
11	2806204	Bearing 6204 2RS	2
12	G000097	Bearing block	1
13	2806006	Bearing 6006 LLU	1
14	G000098	Cover plate	1
15	G300006	Agitator shaft	1
16	G300007	Seed hopper	1
17	6021017	Distance bush D30/D21 L=17.5	1
18	G000024	Bush	2
19	G300008	Hexagon Shaft	1
20	G300009	Hexagon shaft	1
21	G000019	Divider side plate	2
22	G000020	Divider plate left	4
23	G000021	Divider plate right	4
24	G000022	Cover plate	2
25	G000023	Sprocket 3/8"	1
26	1006016	Bolt M6 x 16	43
27	1008016	Bolt M8 x 16	12
28	1008025	Bolt M8 x 25	4
29	1010040	Bolt M10 x 40	8
30	2506016	Set screw M6 x 16	1
31	1706100	Self-Lock Nut M6	47
32	1708125	Self-Lock Nut M8	15
33	1710150	Self-Lock Nut M10	15
34	2210600	Washer M6	14
35	2210802	Washer M8	4
36	2211001	Large washer M10	9
37	2212000	Washer M20	3
38	2220800	Spring Washer M8	4
39	2612000	Circlip d=20	1
40	2405032	Roll pin Ø5x32	4
41	4160025	Key 6x6x25	1

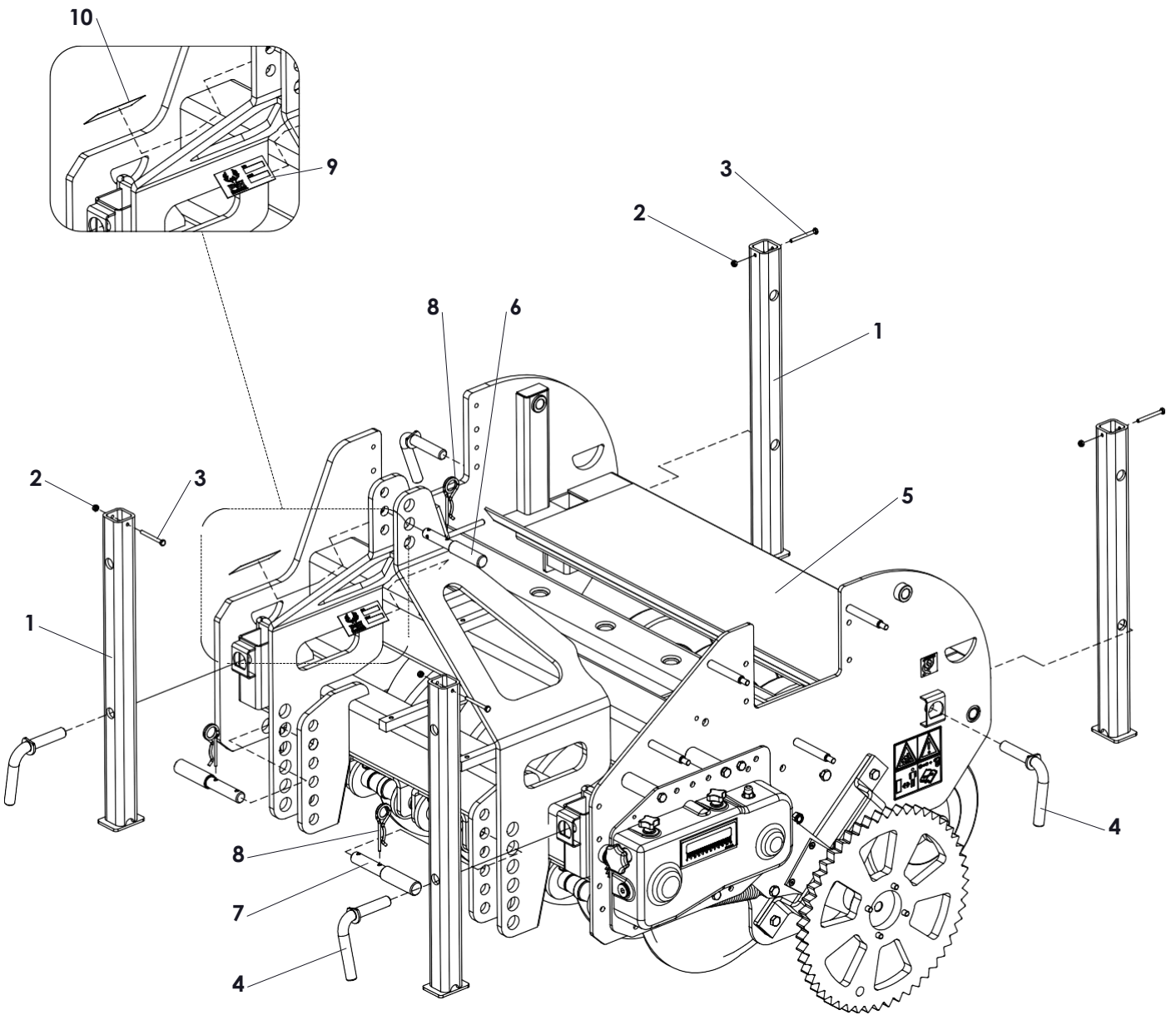

Pos.	Part number	Description	Qty.
1	G000030	Leg	4
2	1706100	Self-Lock Nut M6	4
3	1106060	Bolt M6 x 60	4
4	G000031	Lock pin	4
5	G300010	Rubber grip plate	1
6	3821625	Top link pin	1
7	3822228	3-point pin	2
8	3830500	R-clip Round 5	3
9	4020006	Serial number lable	1
10	4020010	Qr code label	1

2G3-122095200-S01-PP07

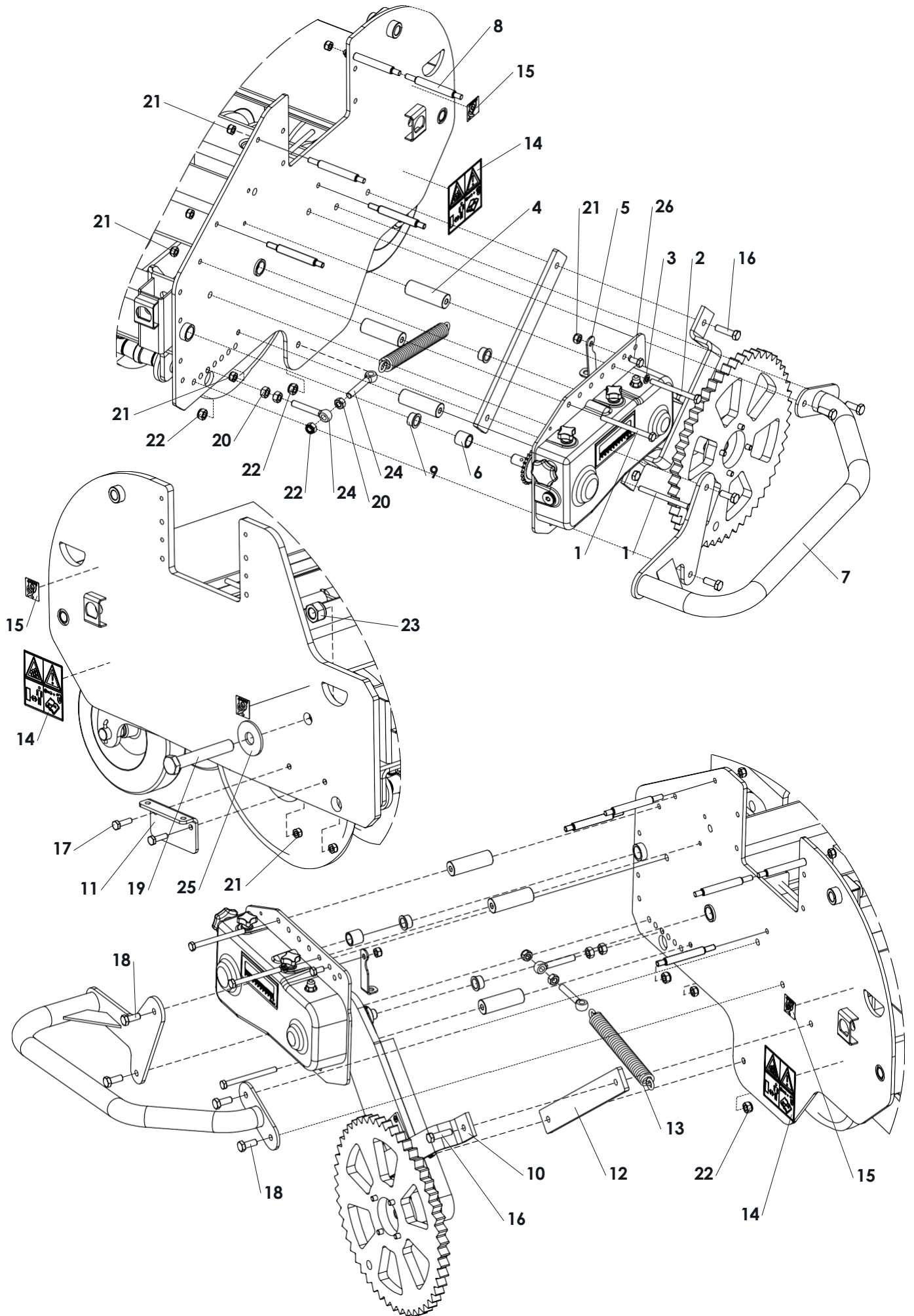

Pos.	Part number	Description	Qty.
1	1110120	Bolt M10 x 120	2
2	1110110	Bolt M10 x 110	1
3	2221000	Spring Washer M10	1
4	6011910	Spacer	3
5	G000033	Sensor bracket	1
6	6021260	Bush	1
7	G300031	Gearbox protection	1
8	G000032	Stud Ø15 L=134	4
9	3220150	Bearing bush	1
10	G000034	Guide swingarm	1
11	G300011	Support	1
12	G000042	Guide bar side plate	1
13	3630250	Spring wheel axle	1
14	4010003	Safety decal	2
15	4020002	Decal fixation point	3
16	1112045	Bolt M12 x 45	2
17	1010035	Bolt M10 x 35	2
18	1012030	Bolt M12 x 30	4
19	1024150	Bolt M24 x 150	1
20	1812175	Nut M12	3
21	1710150	Self-Lock Nut M10	11
22	1712175	Self-Lock Nut M12	8
23	1724200	Self-Lock Nut M24	1
24	4212080	Eye Bolt M12x80	2
25	2212401	Large washer M24	1
26	1010020	Bolt M10 x 20	1

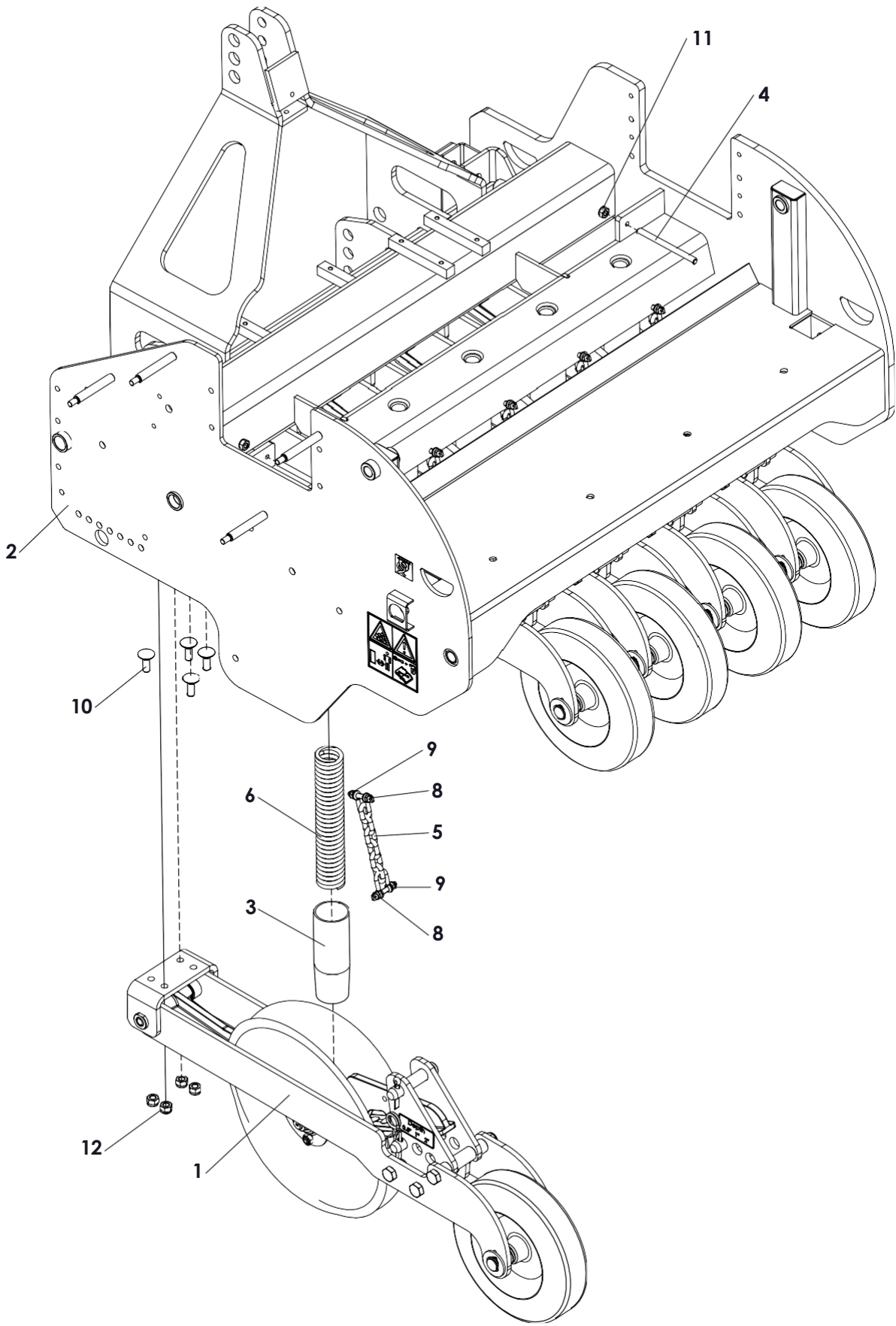

Pos.	Part number	Description	Qty.
1	See page 10	Seed element	5
2	G300012	Frame G3	1
3	G000041	Seed guide	5
4	2310170	Threaded rod M10	2
5	3510806	Chain 6-links D=8mm	5
6	3705040	Compression spring	5
7	3520800	D-Shackle d=8mm complete with bolt and nut	10
8	1008045/10.9	Bolt M 8 x 45	10
9	1708125	Self-lock Nut M 8	10
10	1312035	MH Bolt M12 x 35 from serial number 233029	20
10	1014035	Bolt M14 x 35 till serial number 233028	10
11	1710150	Self-Lock Nut M10	11
12	1712175	Self-Lock Nut M12 from serial number 233029	20
12	1714200	Self-Lock Nut M14 till serial number 233028	10

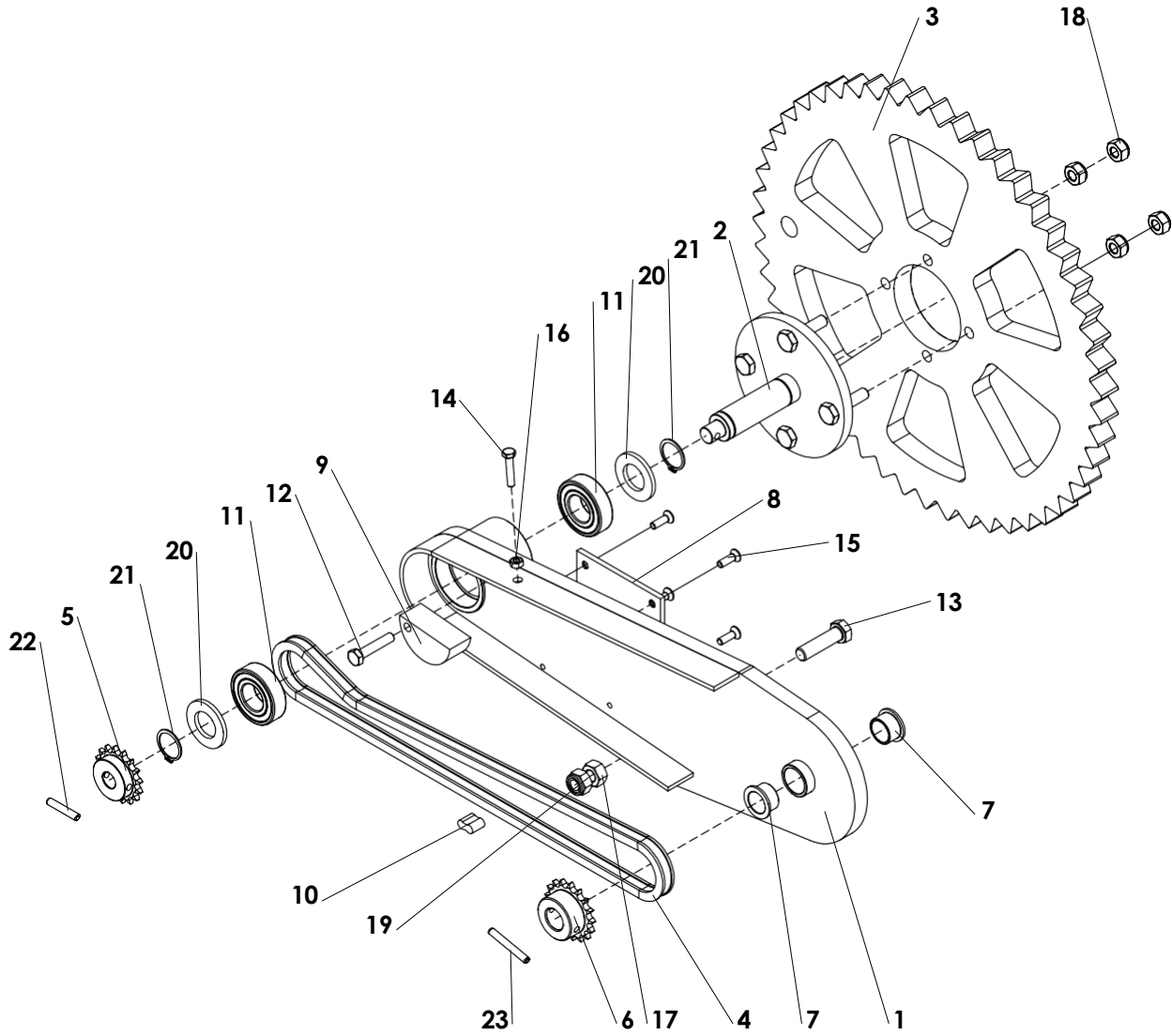

Pos.	Part number	Description	Qty.
1	G000035	Frame swingarm	1
2	G000036	Wheel hub	1
3	G000038	Drive wheel	1
4	3338106	Chain 3/8"	1
5	G000039	Sprocket 3/8" (06B) simplex 16Z	1
6	G000040	Sprocket 3/8" (06B) simplex 17Z	1
7	3220152	Bearing bush swingarm	2
8	G000044	Guide plate swingarm	1
9	G000043	Chain tensioner	1
10	3438000	Chain connector 3/8"	1
11	2806205	Bearing 6205-LLU	2
12	1108040	Bolt M8 x 40	1
13	1112045	Bolt M12 x 45	1
14	1006030	Bolt M6 x 30	1
15	1410620	Bolt M6 x 20	4
16	1806100	Nut M6	1
17	1812175	Nut M12	1
18	1710150	Self-Lock Nut M10	4
19	1712175	Self-Lock Nut M12	1
20	2212400	Washer M24	2
21	2612500	Circlip d=25	2
22	2406035	Roll Pin 6 x 35	1
23	2406045	Roll Pin 6 x 45	1

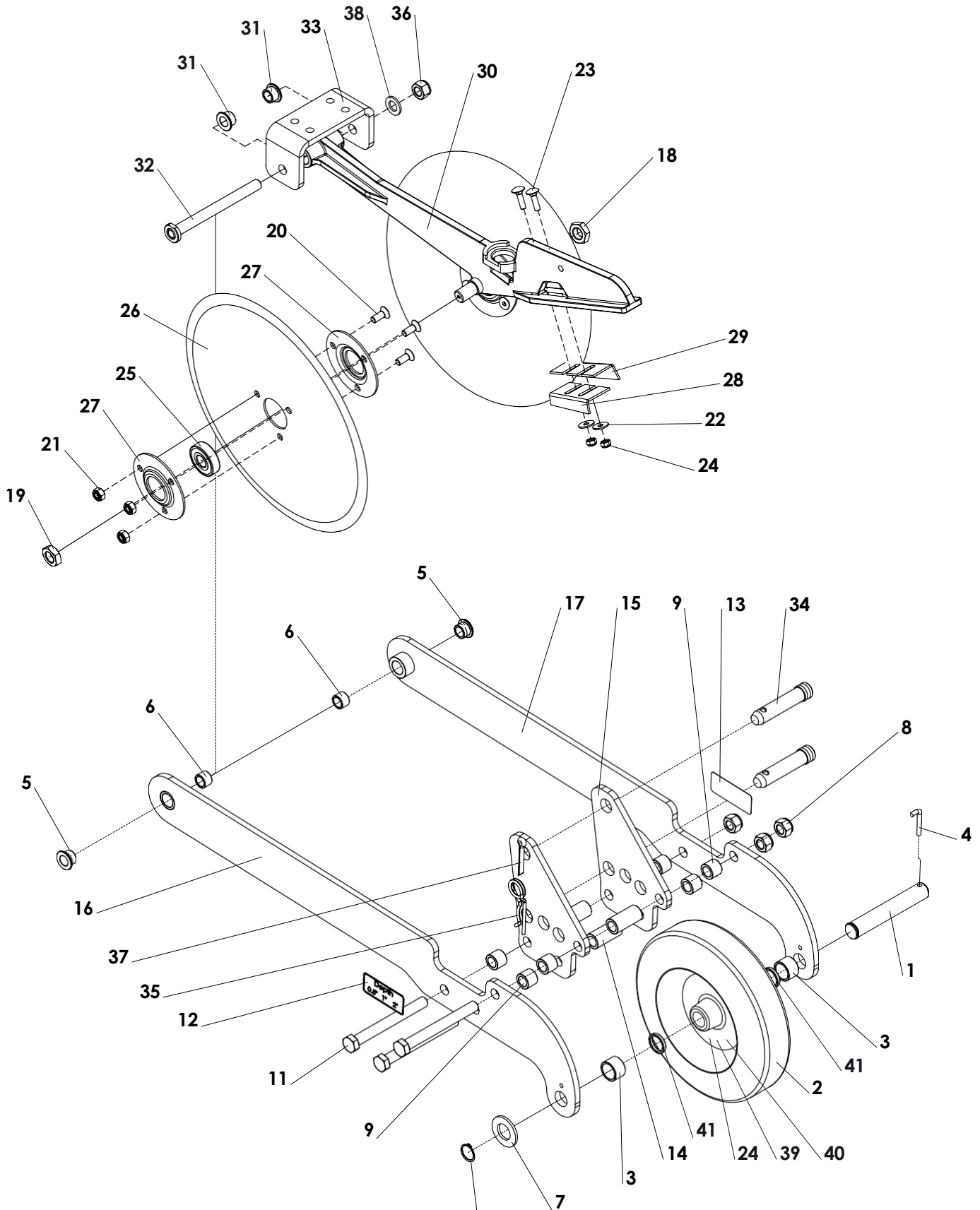

Seed elements per machine G3 : 5 elements

G5 : 8 elements

G8 : 13 elements

G10: 16 elements

!!! wheel replaced from serial nr G3 233079/G5 235222/G8 238032/G10 231005

Pos.	Part number	Description	Qty.
1	G000045	Shaft	1
2	4328071	Wheel complete Will replace item nr 4328070	1
3	6025020	Distance bush	2
4	3830648	Lock pin	1
5	3216150	Bearing bush	2
6	3216155	Bearing bush	2
7	2212700	Washer 27 mm	1
8	1716200	Self-Lock Nut M16	3
9	6017020	Bush Ø16.5/Ø25 L=20	6
10	2612500	Circlip d=25	1
11	1116150	Bolt M16 x 150	3
12	4020003	Depth decal left	1
13	4020004	Depth decal right	1
14	6017052	Distance bush Ø25/Ø16.5 L=52	3
15	G000046	Height plate	2
16	G000047	Weldment seed element left	1
17	G000048	Weldment seed element right	1
18	1820002	Thin Nut M20 Right Hand Thread	1
19	1820002L	Thin Nut M20 Left Hand Thread	1
20	1411025	Bolt M10 x 25	6
21	1710150	Self-Lock Nut M10	6
22	2210801	Large washer M8	2
23	1308030	MH Bolt M8 x 30	2
24	1708125	Self-Lock Nut M8	2
25	2806304	Bearing 6304-LLU	2
26	G000049	Cutting disk Ø406	2
27	G000050	Center plate	2
28	G000051	Disc Scraper Large	1
29	G000052	Disc Scraper Small	1
30	G000053	Element	1
31	3216150	Bearing bush	2
32	G000054	Seeding element shaft	1
33	G000055	U holding bracket	1
34	3822112	Pin	2
35	3830500	R-clip Round 5,	1
36	1716200	Self-Lock Nut M16	1
37	2408050K	Cotter Pin 8 x 50	1
38	2211600	Washer M16	1
39	1008016	Bolt M 8 x 16	6
40	2806205	Bearing 6205 2RS	2
41	6025005	Distance washer	2

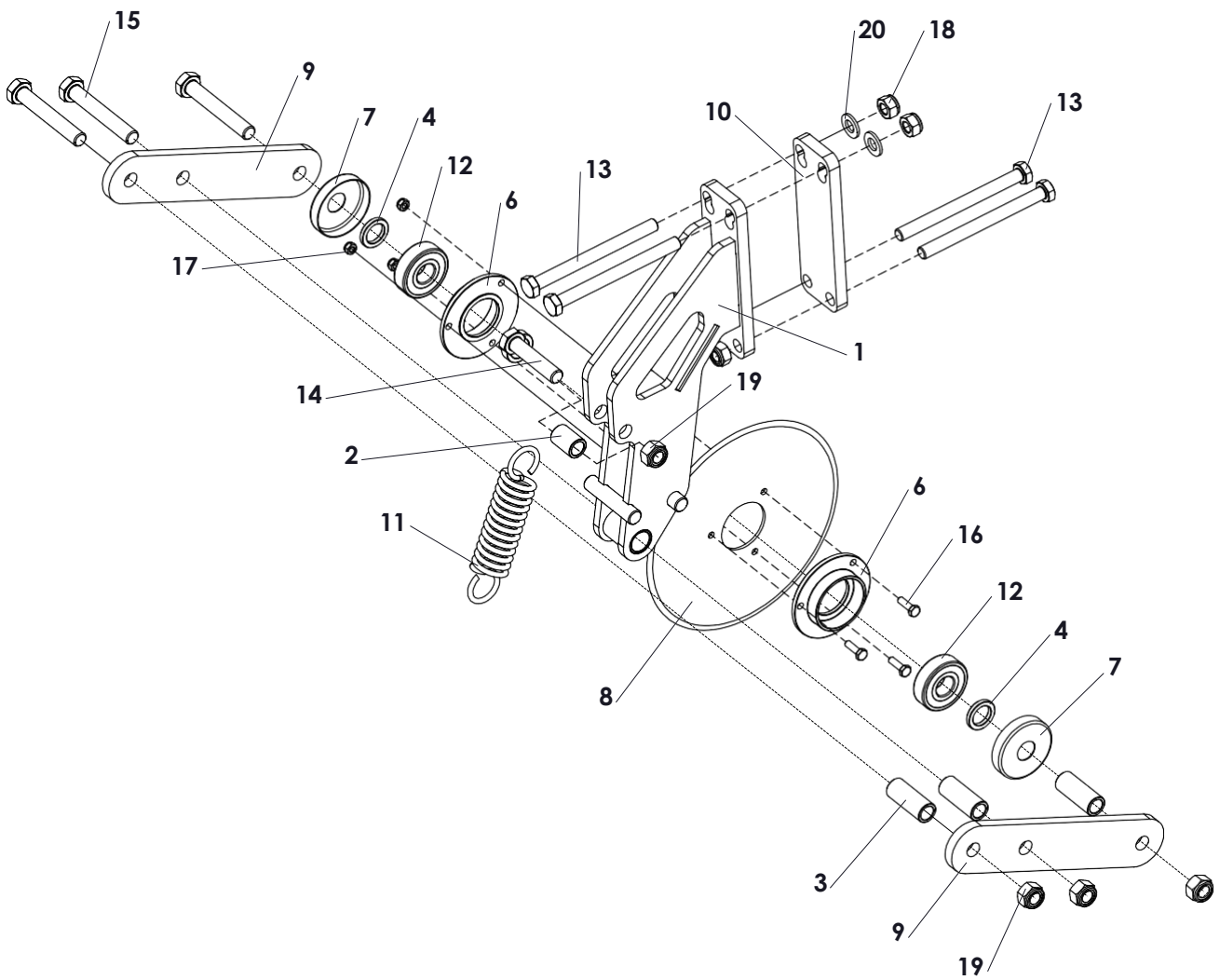

Coultter kits per machine

- G3 : 5 kits
- G5 : 8 kits
- G8 : 13 kits
- G10: 16 kits

Pos.	Part number	Description	Qty.
1	G000056	Support bracket	1
2	6014290	Distance bush Ø20/Ø14.2 L=29	1
3	6014500	Distance bush Ø20/Ø14.2 L=50	3
4	6021045	Distance bush	2
5	6021009	Distance bush Ø30/Ø20.5 L=9	1
6	G000057	Bearing block	2
7	G000058	Dust cover	2
8	G000059	Disc Ø220/ 3mm	1
9	G000060	Arm	2
10	G000061	Lock plate	1
11	3640127	Spring	1
12	2806304	Bearing 6304-LLU	2
13	1112140	Bolt M14 x 140	4
14	111406510.9	Bolt M14 x 65	1
15	1114090	Bolt M14 x 90	3
16	1006020	Bolt M6 x 20	3
17	1706100	Self-Lock Nut M6	3
18	1712175	Self-Lock Nut M12	4
19	1714200	Self-Lock Nut M14	4
20	2211200	Washer M 12	2
	GDO-04	Coulter knife kit include pos. 1 till 20	

G3 need 5 coulter kits for the complete machine
G5 need 8 coulter kits for the complete machine
G8 need 13 coulter kits for the complete machine
G10 need 16 coulter kits for the complete machine

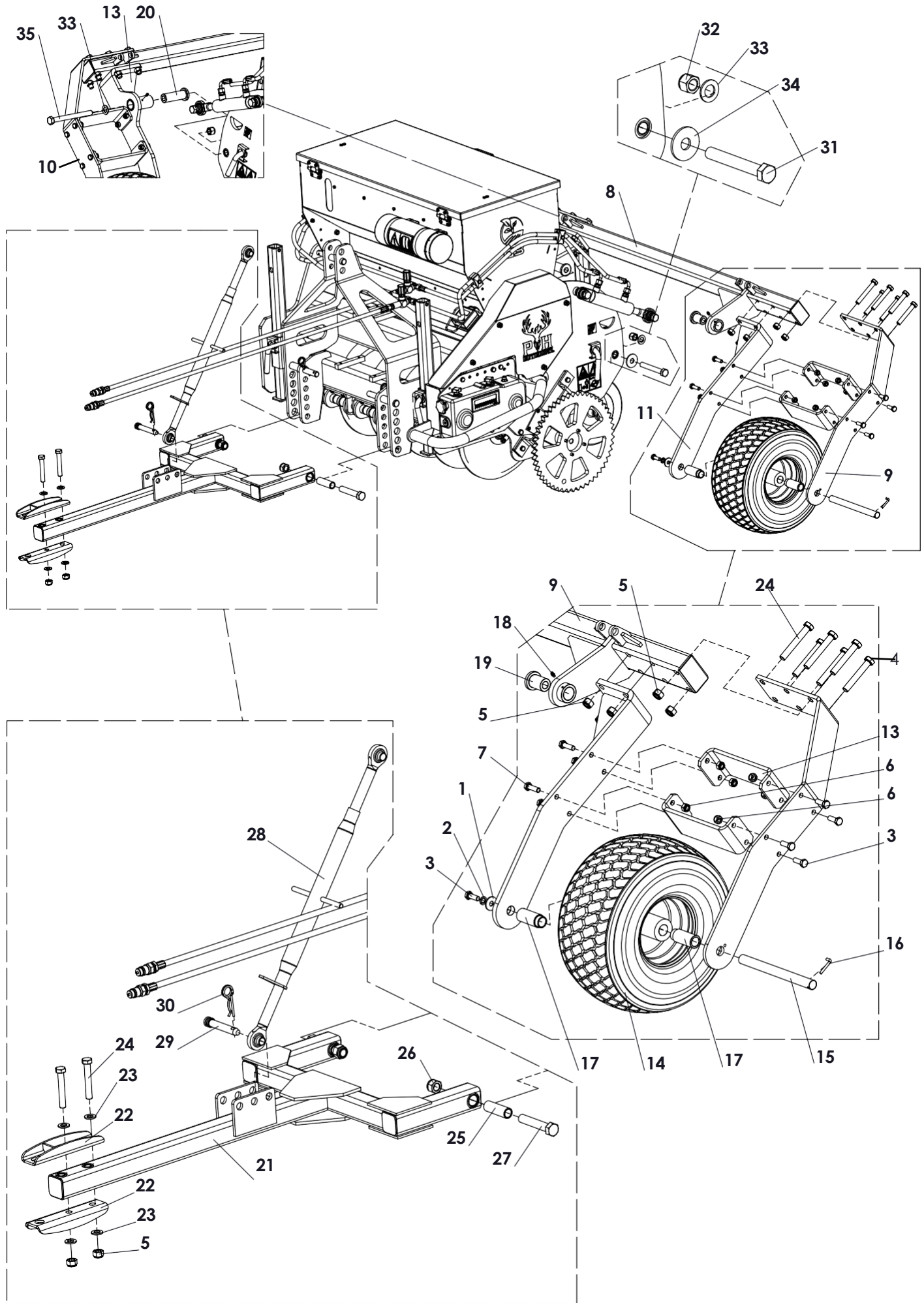

Pos.	Part number	Description	Qty.
1	2211201	Large washer M12	2
2	2221200	Spring Washer M12	2
3	1012035	Bolt M12 x 35	10
4	1116110	Bolt M16 x 110	8
5	1716200	Self-Lock Nut M16	12
6	1712175	Self-Lock Nut M12	16
7	1012040	Bolt M12 x 40	8
8	G300013	Main beam	1
9	G300014	Wheel support long	1
10	G300015	Wheel support long	1
11	G300016	Inner support wheel boggy	1
12	G300017	Inner support wheel boggy	1
13	G300018	U-Bridge	4
14	4318958	Wheel 18x9.5x8	2
15	G300030	Wheel Shaft	2
16	3836048	Lock pin	2
17	6025700	Distance Bush Wheel	4
18	4406180	Grease nipple M6	2
19	6020102	Collar bush Ø50/Ø34.8 Ø19.5 L=102	1
20	6020060	Collar bush	1
21	G300019	Drawbar	1
22	G300020	Tow eye	2
23	2211600	Washer M16	4
24	1116100	Bolt M16 x 100	2
25	6022085	Distance bush Ø28/Ø22 L=85	2
26	1722250	Self-Lock Nut M22	2
27	1122120	Bolt M22 x 120	2
28	3811970	Toplink	1
29	3821912	Top Link Pin	1
30	3830500	R-clip Round 5	1
31	1634140	Hex Bolt 3/4-16 L=5.5 UNC	4
32	1934001	SL Nut 3/4"-16 UNF	2
33	2212000	Washer M20	6
34	2212001	Large washer M20	1
35	1634200	Hex Bolt 3/4-16 L=8 UNC	1

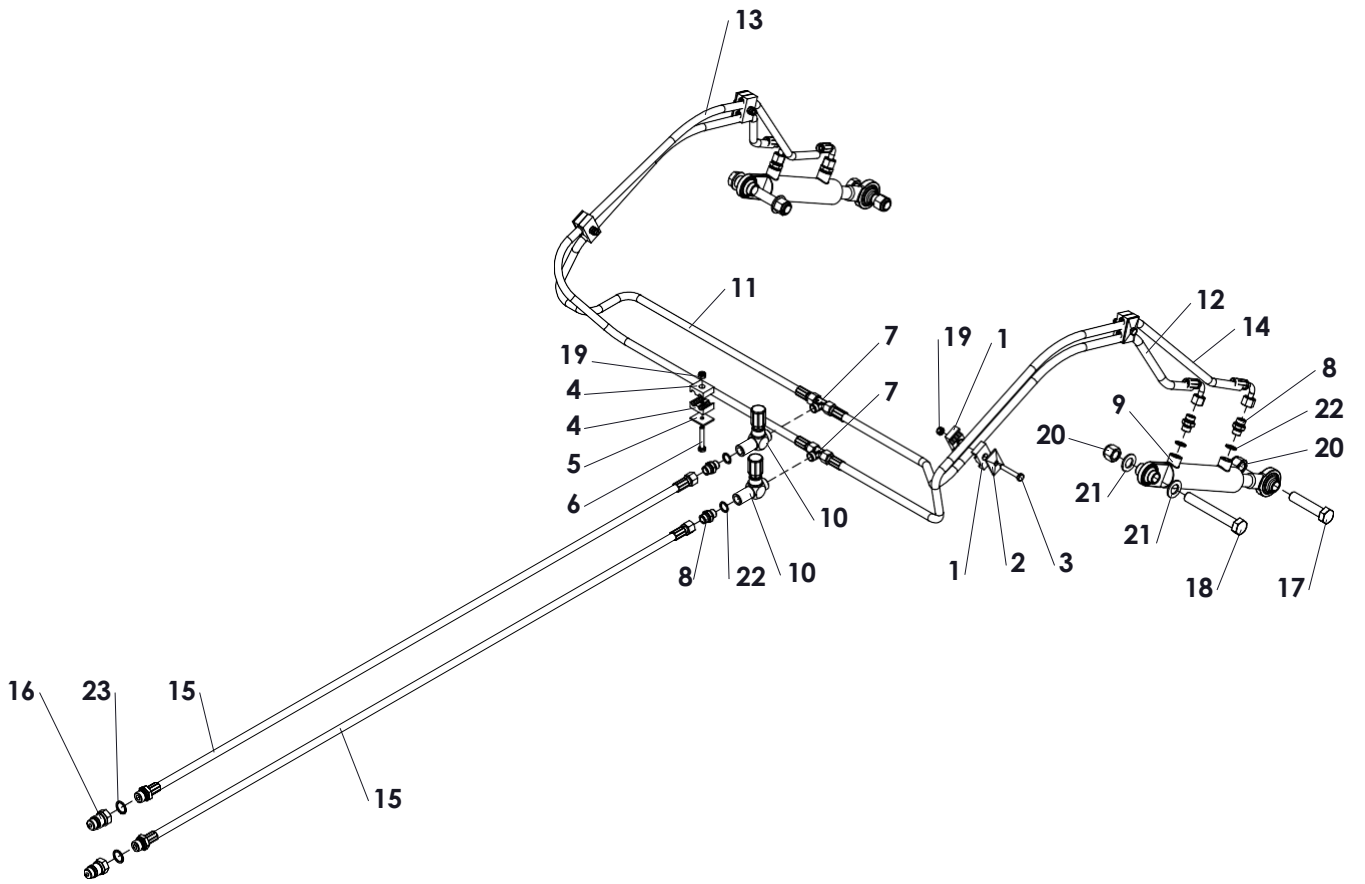
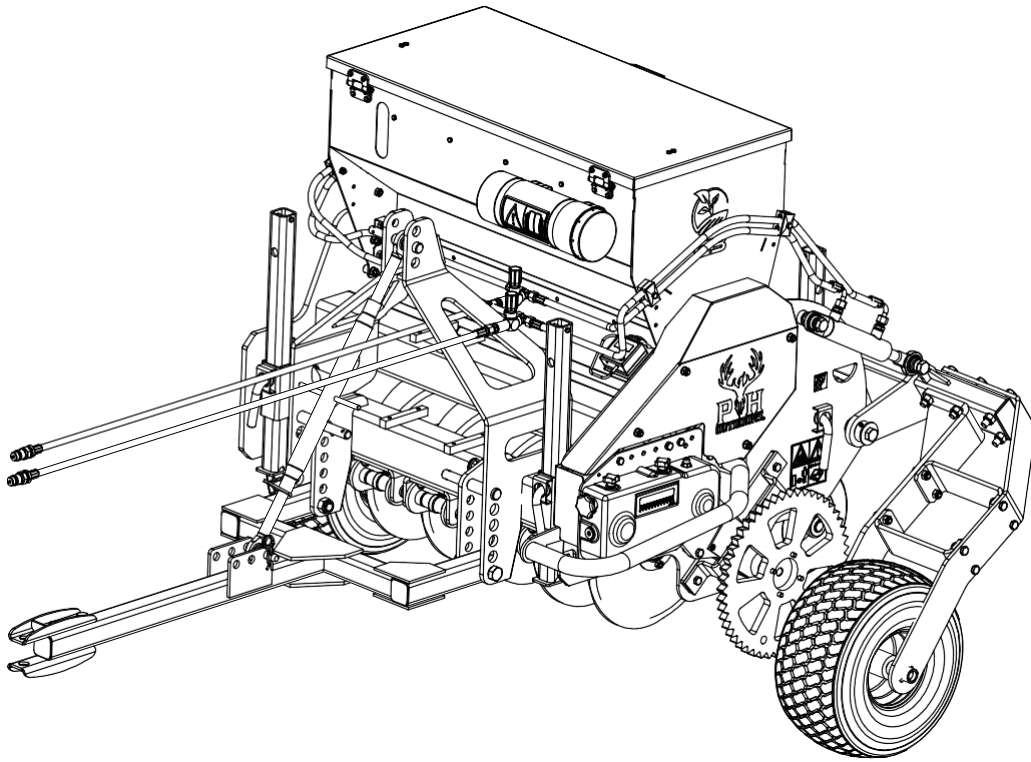

Pos.	Part number	Description	Qty.
1	8015150	Hose clamp 15 mm	16
2	8015151	Cover plate hoe clamp 15 mm	4
3	1108050	Bolt M8 x 50	8
4	8015150	Hose clamp 12mm	2
5	8015151	Cover plate hose clamp	1
6	1108065	Bolt M8 x 65	1
7	8112121	T-Connector 12x12x12	2
8	8238120	Nipple BSP 3_8" x pipe 12 (M18)	1
9	8800005	Hydraulic cylinder 25-40 stroke 125mm L0=386	2
10	8800002	Flow reducer 3/8" FPU05001	2
11	G300021	Hose NSK-10 TL=1860 1xPGLO1018 + 1xPGLO101890	1
12	G300021	Hose NSK-10 TL=1860 1xPGLO1018 + 1xPGLO101890	1
13	G300024	Hose NSK-10 TL=1950 1xPGLO1018 + 1xPGLO101890	1
14	G300024	Hose NSK-10 TL=1950 1xPGLO1018 + 1xPGLO101890	1
15	G300025	Hose NSK10-3/8" TL=3000 PGLO1018 + PN108	2
16	8800001	Quick connector male 1/2"	2
17	1634089	Hex Bolt 3/4-16 L=3.5 UNF	2
18	1634140	Hex bolt 3/4-16 L=.5.5 UNF	2
19	1708125	Self-Lock Nut M8	9
20	1934001	SL Nut 3/4"-16 UNF	4
21	2212000	Washer M20 - ISO 7089	10
22	2233800	Copper washer 3_8	2
23	2231200	Copper washer 1_2	2

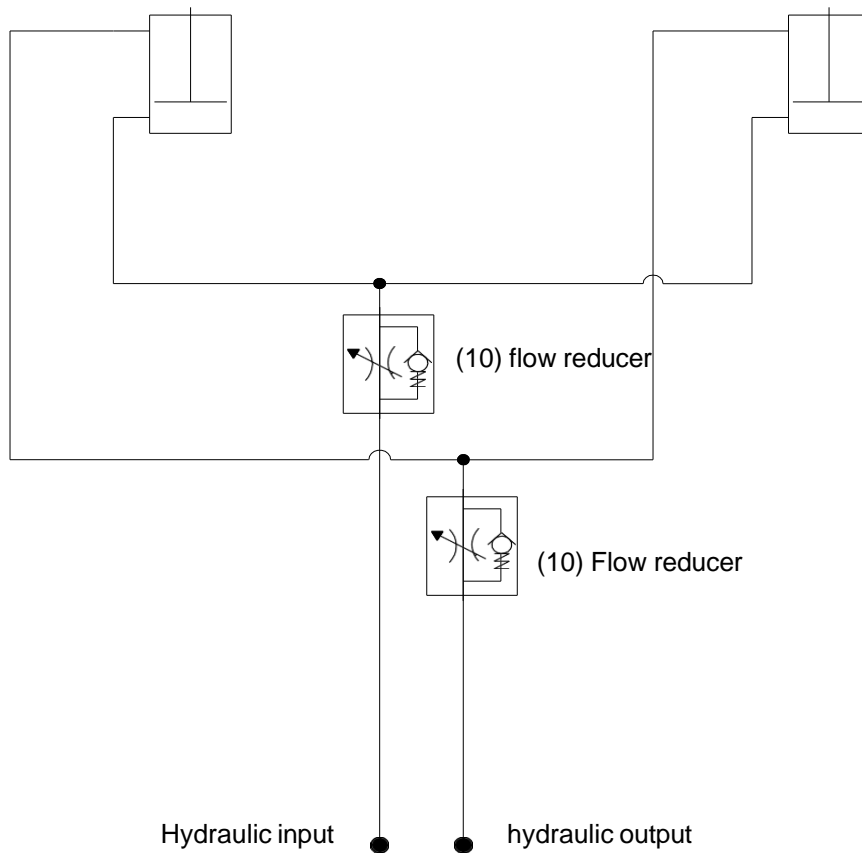

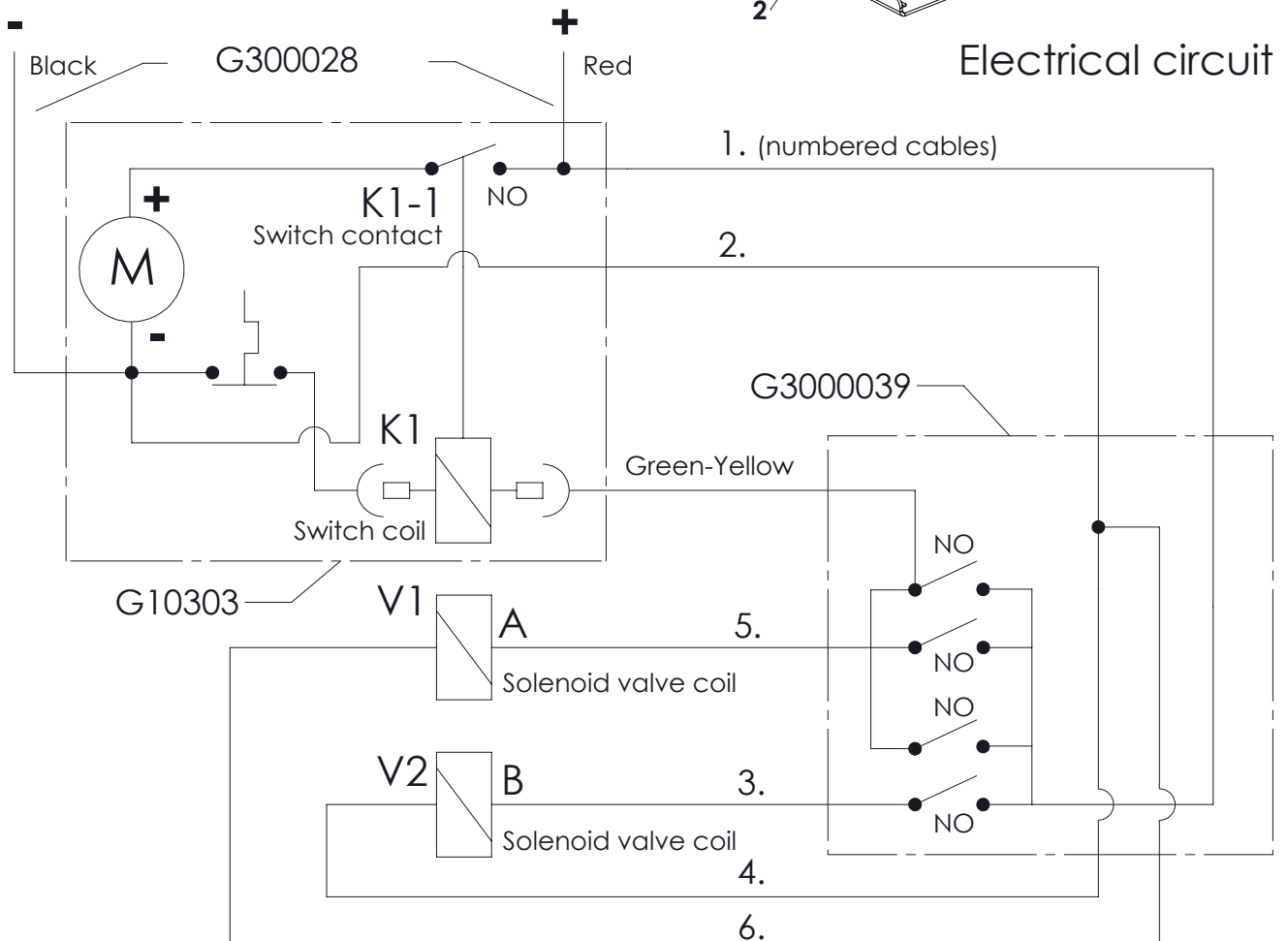
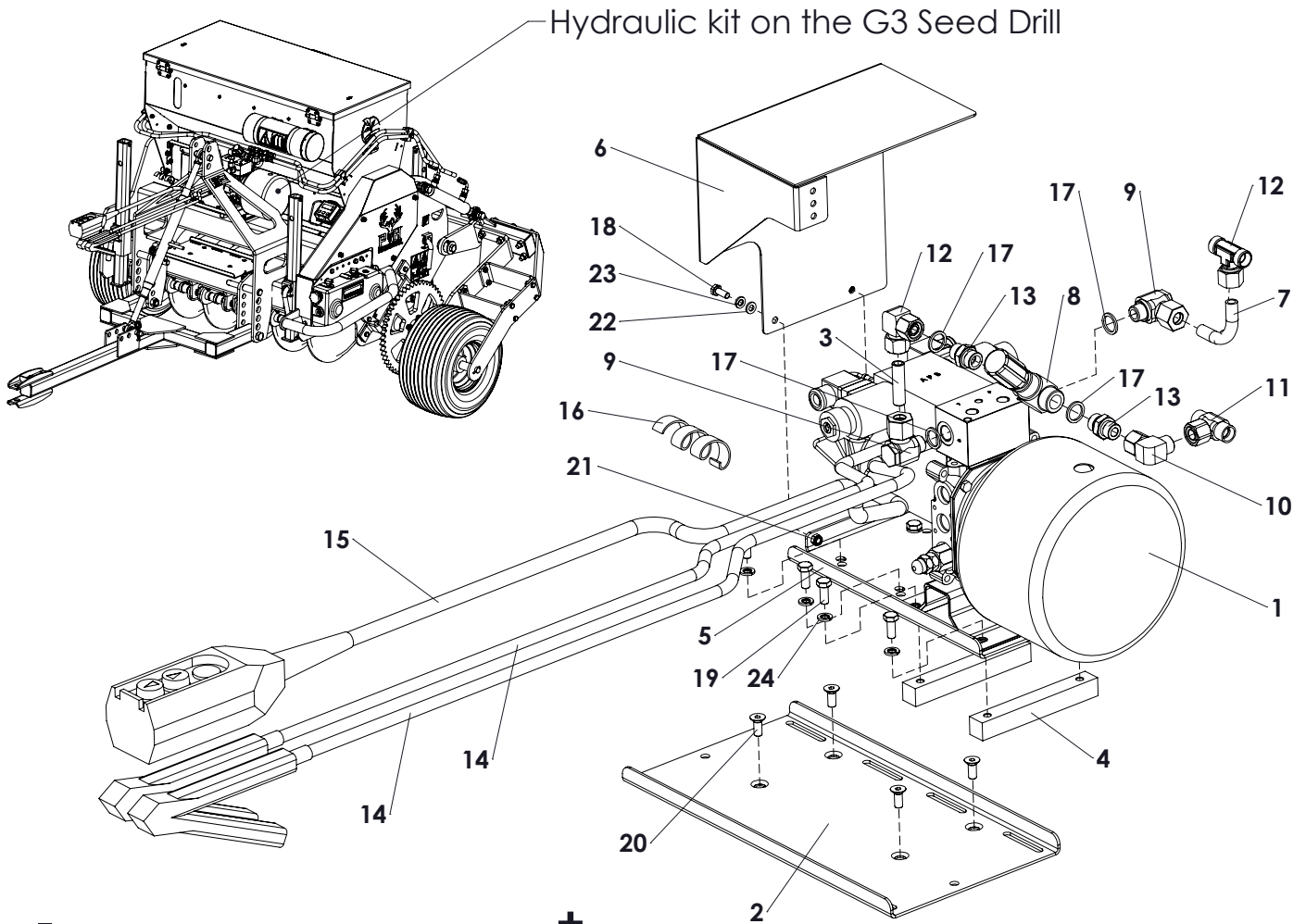

If the cylinder does not move in the right direction, the connection of solenoid valve must be replaced.

Item	Part number	Description	Article number	Qty.
1	G10303	Hydraulic pump + oil tank		1
2	G300027	Accu tray		1
3	G100048	Tube 12 x 45		1
4	G300035	Square 20x20 with holes		2
5	G300036	Hydr. motor mounting plate		1
6	G300037	Coverplate		1
7	G300038	Tube 12 x 90 degree L=75		1
8	8800002	Flow reducer 3/8" FPU05001		1
9	8438120	L-connector G3/8-12mm		2
10	8312121	L-Connector PM, Pipe 12-M18		2
11	8112123	T_-Connector PM, Pipe 12-M18		1
12	8112122	T-Connector 12x12x12 + nut		1
13	8238120	Nipple BSP 3_8" x pipe 12 (M18)		2
14	G300028	Cable set 4.5mtr		1
15	G300039	Electric control unit		1
16	3900004	Protection sleeve L=500mm		1
17	2233800	Copper washer 3_8		4
18	1006016	Bolt M6 x 16		2
19	1008020	Bolt M8 x 20		8
20	1410820	Bolt M8 x 20		4
21	1706100	Self Lock Nut M6		2
22	2210600	Washer M6		2
23	2220600	Spring Washer M6		2
24	2220800	Spring Washer M8		8

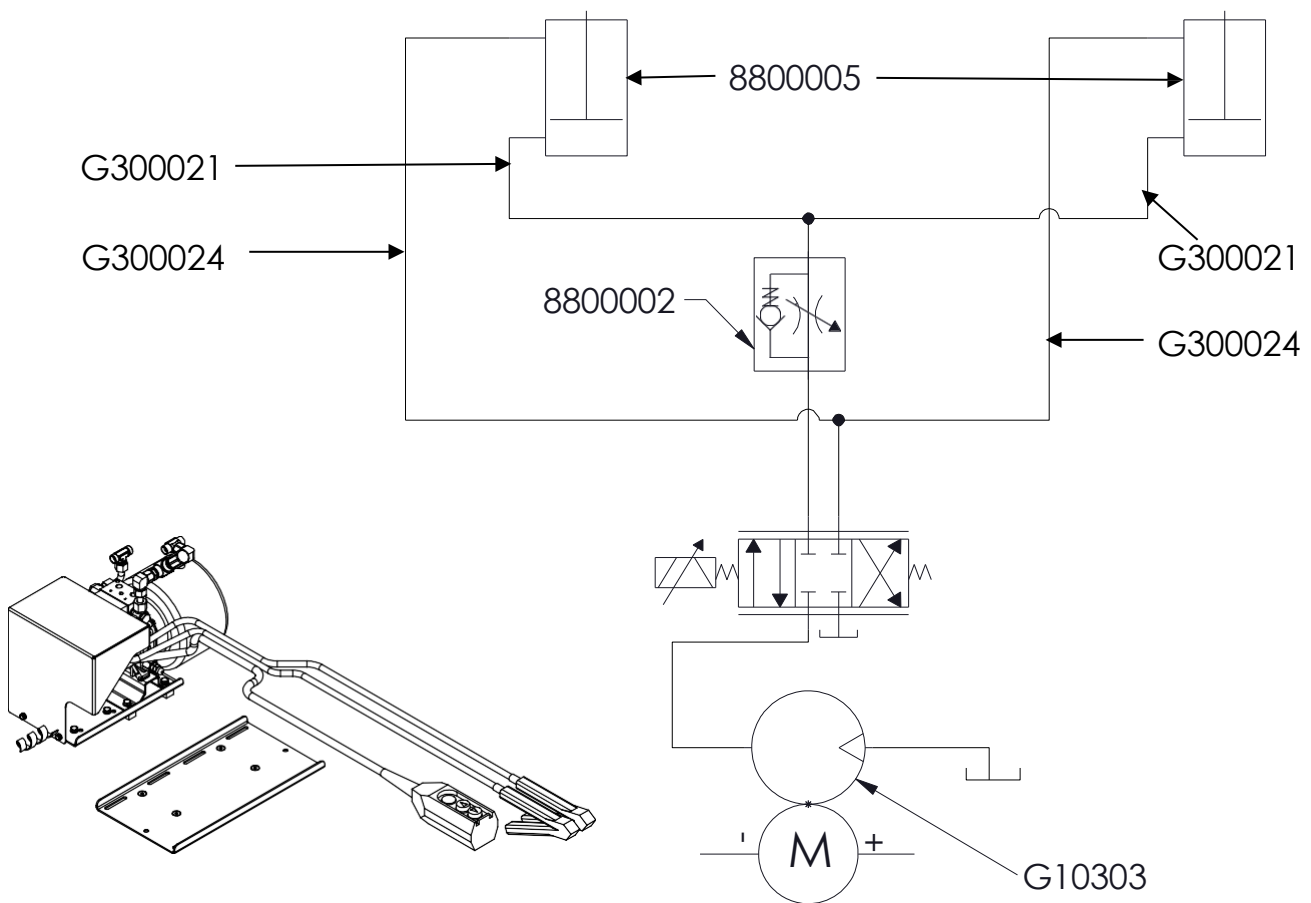

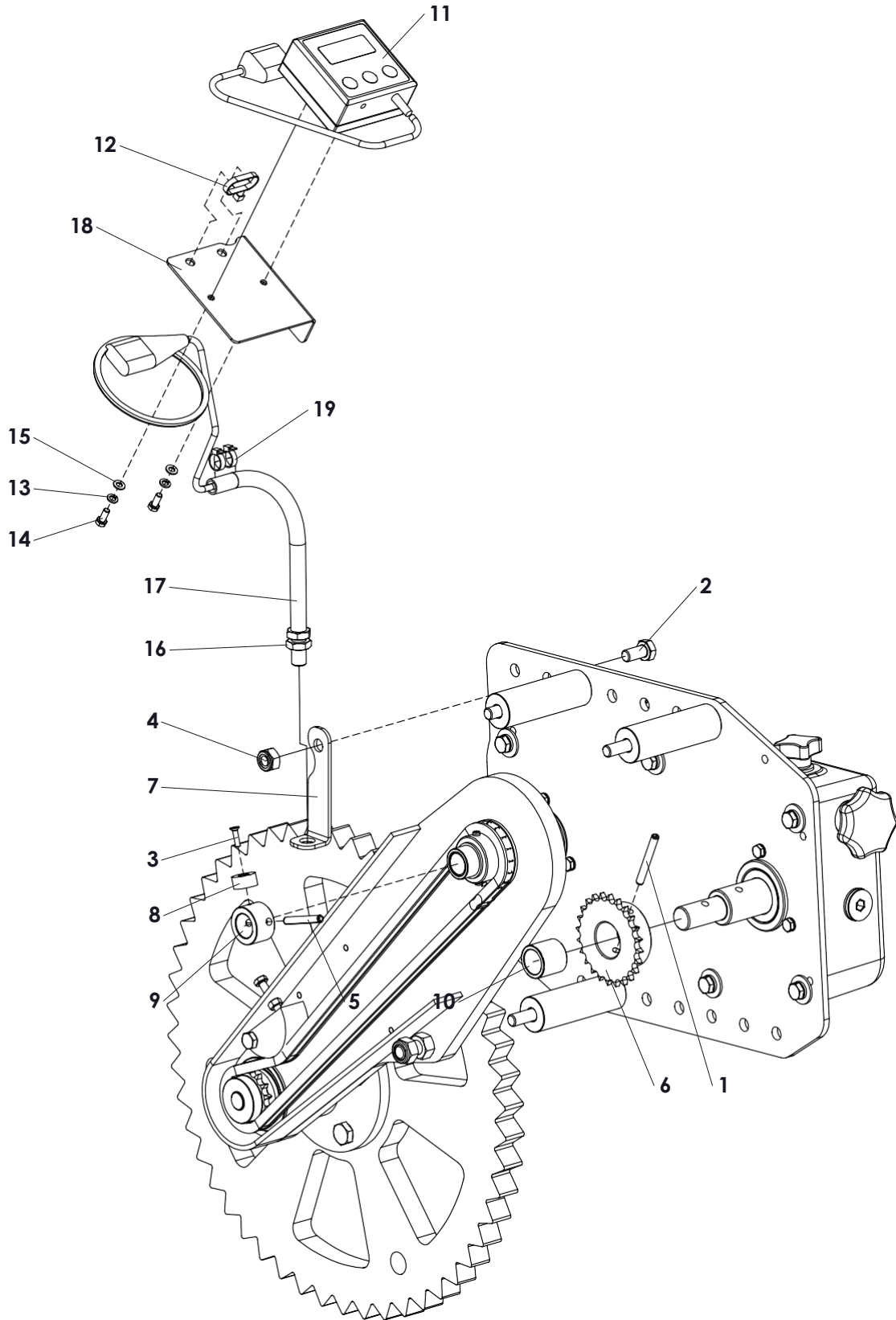

Pos.	Part number	Description	Qty.
1	2406050	Roll pin 6 x 50	1
2	1010020	Bolt M10 x 20	1
3	1410416	Bolt M4 x 16	1
4	1710150	Self-lock Nut M10	1
5	2406045	Roll pin 6 x 45	1
6	G000083	Sprocket Z 24	1
7	G000033	Sensor bracket	1
8	G000084	Magnet	1
9	G000085	Magnet bush	1
10	G000086	Bush	1
11	G000087	Counter UC300	1
12	3900007	Cable tie 4.8x200	1
13	2220500	Spring washer M5	2
14	1005012	Bolt M 5 x 12	2
15	2210500	Washer M5	2
16	G000088	Magnetic sensor D10+cable +magnet	1
17	3900006	Protection tube	1
18	G000089	Bracket Counter	1
19	3900007	Cable tie 4.8x200	2

Gearbox assembly

DETAIL A

SCALE 1 : 3

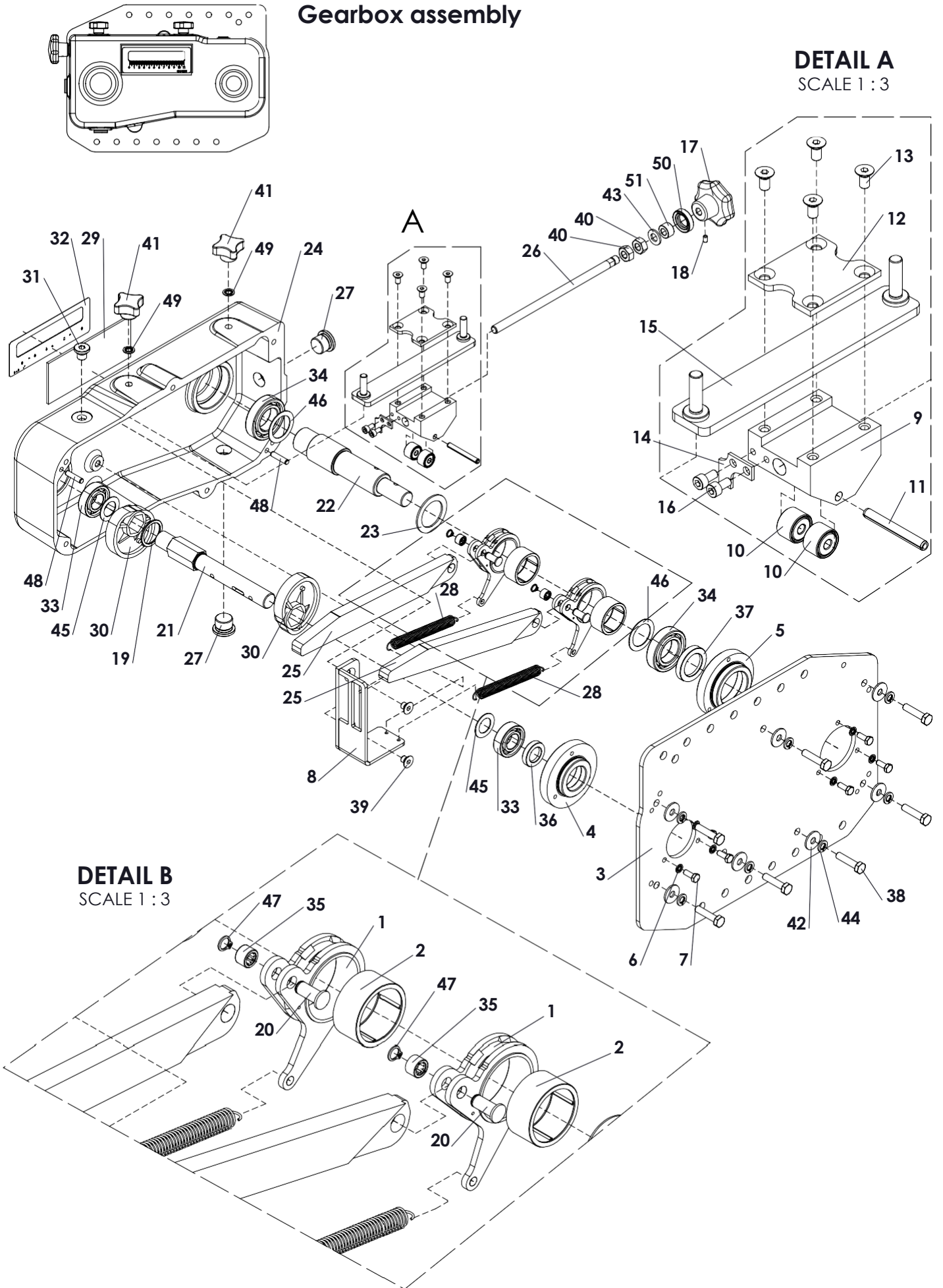

Pos.	Part number	Description	Qty.
1	G000025	Rocker arm	2
2	2703520	Bearing HF3520	2
	G000093	Rocker arm assy include pos.1+2	2
3	G000062	Gearbox back plate	1
4	G000091	Bearing hub 42 mm	1
5	G000092	Bearing hub 55 mm	1
6	2250600	Bonded seal ring M6	6
7	1006016	Bolt M 6 x 16	6
8	G000063	Guide plate	1
9	G000064	Slider block	1
10	2700612	Roller bearing	2
11	2406050	Roll Pin 6 x 50	1
12	G000067	Lock plate	1
13	1410612	Bolt M6 x 12	4
14	G000068	Indicator	1
15	G000069	Slider bracket	1
16	1420510	Inner hexagon bolt M5 x 10	2
17	G000070	Knurled knob M10x63	1
18	2505008	Set screw M5 x 8	1
19	G000071	Spacer	1
20	G000072	Pin	2
21	G000073	Shaft	1
22	G000074	Shaft	1
23	G000075	Washer	1
24	G000076	Casted gearbox housing	1
25	G000077	Rocker strip	2
26	G000078	Threaded rod M10x210	1
27	8712001	Blind plug G1/2	2
28	G000079	Spring	2
29	G000080	Window	1
30	G000081	Ex center	2
31	8714001	Blind plug from serial number 24..... before this it was a breather 8714002	1
32	G000082	Gauge decal	1
33	2706004	Bearing 6004	2
34	2706006	Bearing 6006	2
35	2700808	Bearing HK0808	2
36	7020320	Oil seal 20-32-7	1
37	7030450	Oil seal 30-45-8	1
38	1008035	Bolt M8 x 35	7
39	1410810	Bolt M8 x 10	2
40	1810150	Nut M10	2
41	1808002	Closed Knob M8	2
42	2210801	Large washer M8	9
43	2211000	Washer M10	1
44	2220800	Spring Washer M8	7
45	2242010	Shim Ø20xØ32x1.0	2
46	2243010	Shim Ø30xØ42x1.0	2
47	2610800	Circlip d=8	2
48	2406026/P	Parallel pin 6 x 26	2
49	2250800	Bonded seal ring M8	2
50	7017290	Oil seal 17x29x7	1
51	G000101	Stainless steel bush M 10 use locktide when mounted on shaft	1
	G000090	Speed adjustable box complete (include pos. 1 till 48)	1

Without side cover

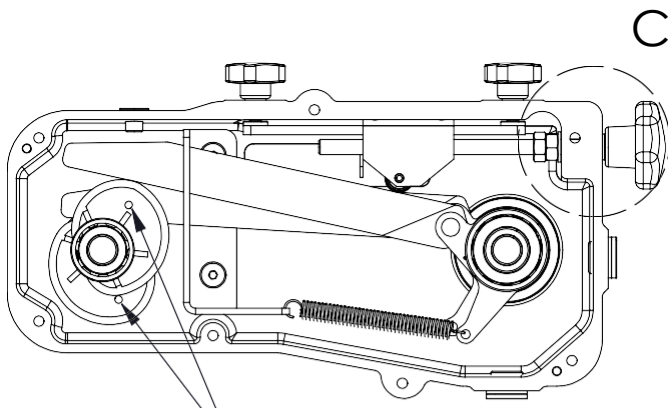

Warning!

Make sure the excenters are positioned correct:

- The nodge has to be faced outwards.
 - Timing: 180° shifted from each other
- If not correctly installed a shocked rotation will occur at the output shaft.

DETAIL C

SCALE 1 : 2

Mount knob as far as possible on threaded rod and adjust set screw

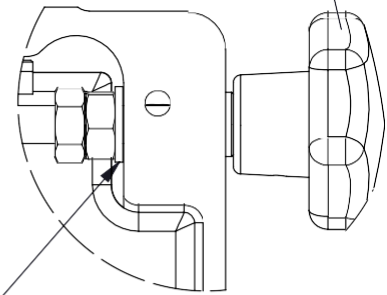

Keep ±2mm clearance distance between washer and casting! Adjustment must rotate smooth.

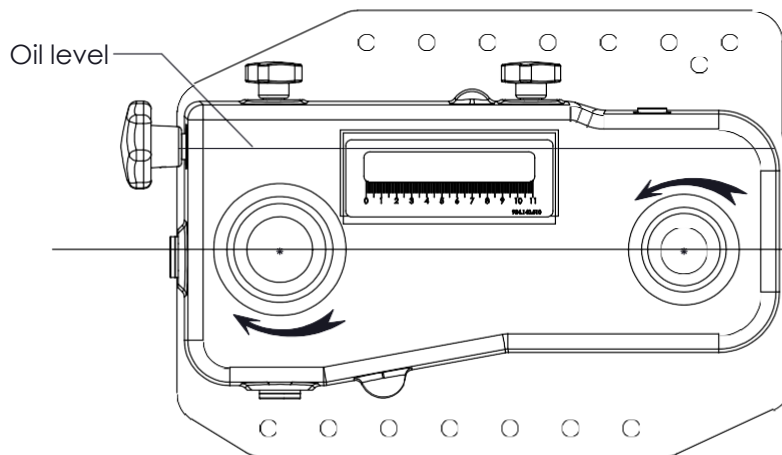

Oil level

Fill gearbox with ±2,5L 80W90 oil
Fill till oil level line.
Check for leakage after filling

SECTION D-D

SCALE 1 : 5

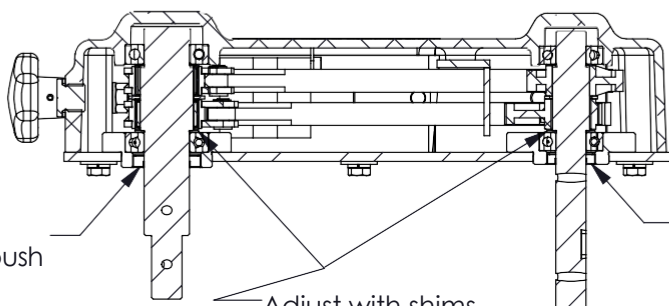

Outside seal even to outside bush

Outside seal even to outside bush

Adjust with shims.
Free play: ±0 - 0.5mm